

N PANEL JACK RG58 CRIMP

SC9355

SPECIFICATIONS

ELECTRICAL:

FREQUENCY: 0-11 GHZ
 VSWR 1.3:1 MAX
 IMPEDANCE: 50 OHMS

MECHANICAL:

MATERIAL BODY: NICKLE PLATED BRASS
 CENTER CONTACT: BeCu
 CONTACT PLATING: 30 μ-in
 INSULATOR: TEFLON
 INTERFACE: MIL-STD-348B
 ROHS COMPLIANT
 OP. TEMP RANGE: -55°C- +110°C

ASSEMBLY INSTRUCTIONS:

TRIM CABLE TO OVERALL LENGTH AS SHOWN;
 SLIDE BACKNUT, WASHER, GASKET, CLAMP ON CABLE;
 COMB BRAID WIRES OUT, FOLD BACK, TRIM FLUSH W CLAMP;
 TRIM DIELECTRIC & CENTER PIN AS SHOWN;
 ASSEMBLE REAR BUSHING;
 SOLDER CONTACT ONTO CENTER CONDUCTOR,
 INSERT ASSEMBLY INTO BODY, TIGHTEN NUT

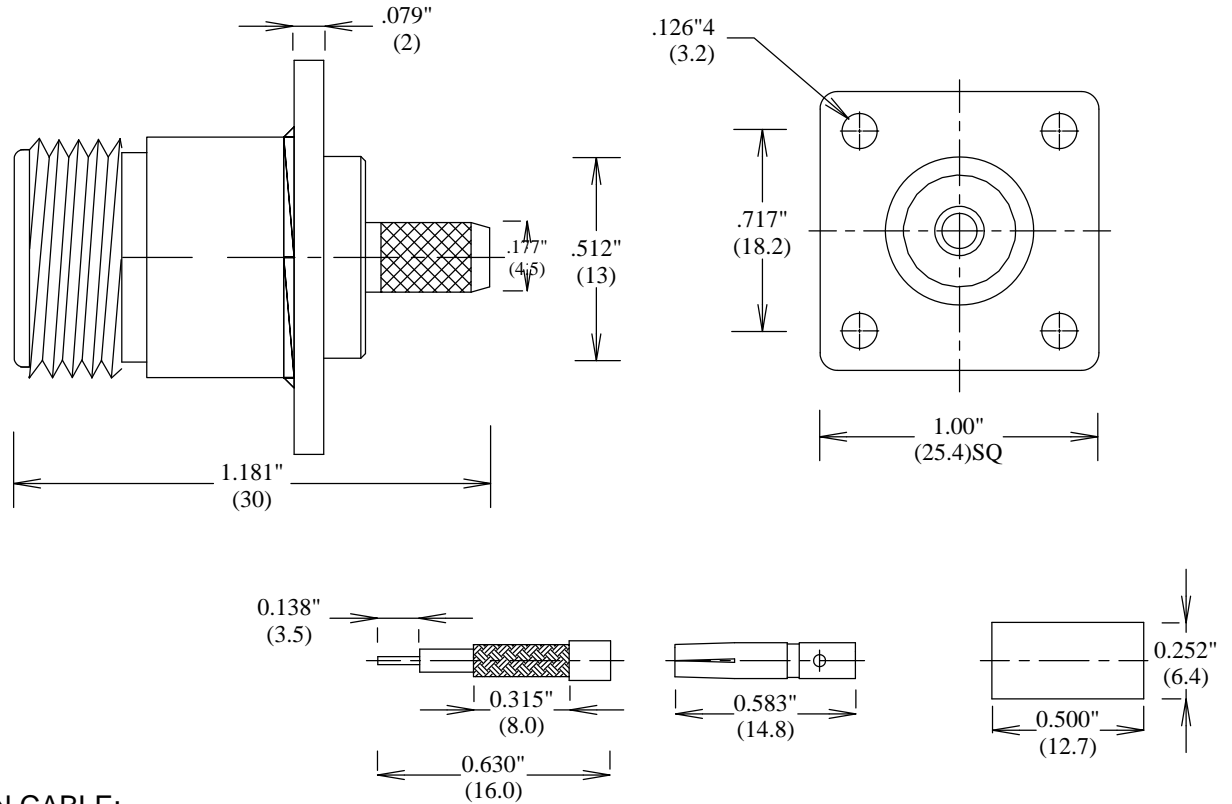

FAIRVIEW MICROWAVE INC.

ALLEN, TX 75013 WWW.FAIRVIEWMICROWAVE.COM

TITLE

N PANEL JACK RG58 CRIMP

SIZE	CAGE CODE	DWG NO	REV
A	3FKR5	SC9355	--
SCALE		SHEET	

ALL DIMENSIONS IN inches(MM) Typical