

COMPONENT	MATERIAL AND FINISH	
HOLDER & PUSHER	303 CRES, ASTM A582	PASSIVATE, QQ-P-35
COLLET	BeCu, ASTM B196, UNS C17300	NICKEL PLATE, QQ-N-290
SPRING	MUSIC WIRE	

PART NO. MMSP-2680

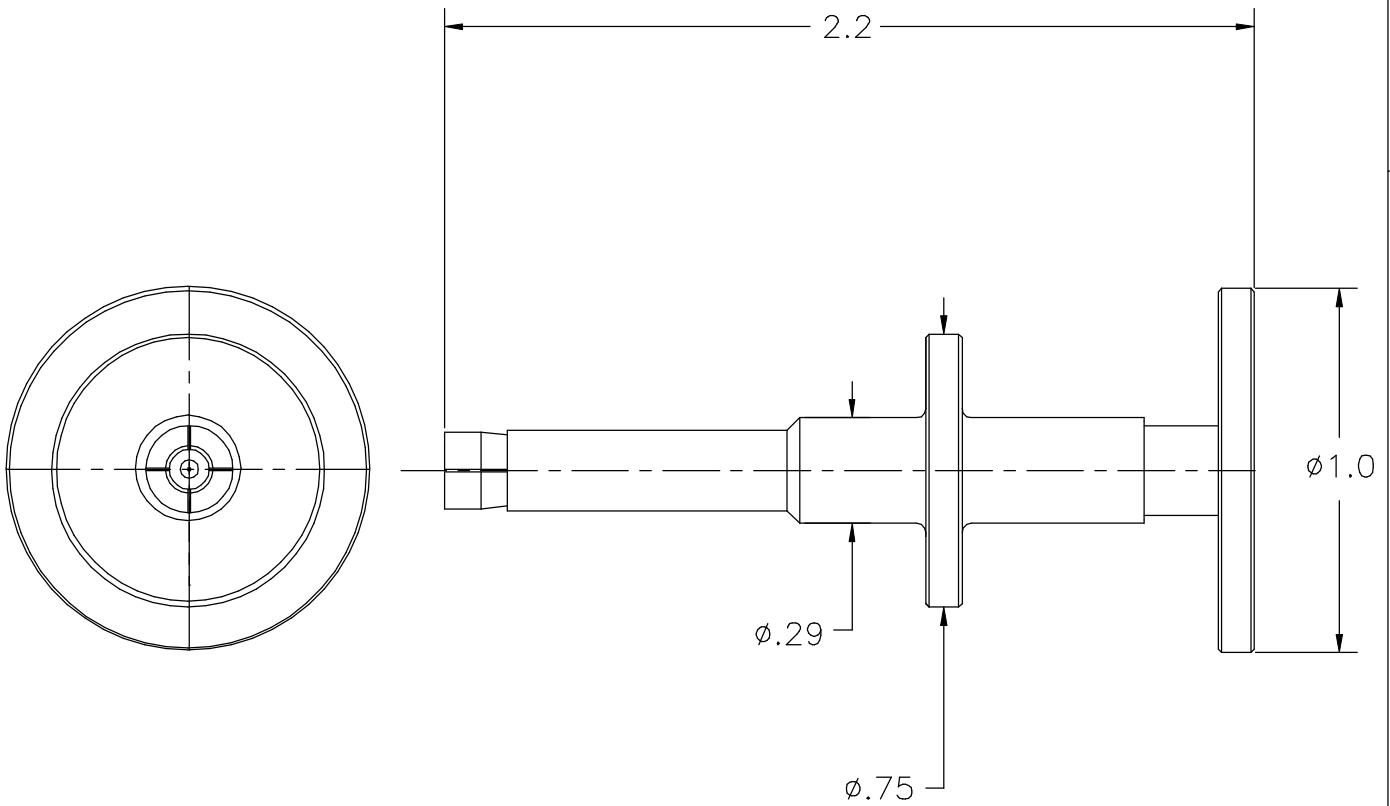

OUTLINE DRAWING



MICRO-MODE PRODUCTS, INC.
The Reliable Connection to the Future

El Cajon, CA 92020 Peoria, AZ 85345
(619) 449-3844 (602) 334-8944

CAGE CODE
15907

INSTALLATION/EXTRACTION TOOL FOR
MMSP BLINDMATE INTERCONNECTS

PART NO.

MMTL-2680

REVISION

—

SHEET 1 OF 1 OL2680 5-18-98 PC PC