

## BNC Male Connector Crimp/Solder Attachment for RG55, RG141, RG142, RG223, RG400 Cable

BNC male connector with crimp/solder attachment for RG55, RG141, RG142, RG223 and RG400, part number FMCN1567, from Fairview Microwave is in-stock and ships same day. This BNC male connector operates up to a maximum frequency of 4 GHz and offers good VSWR of 1.3:1.

Fairview's BNC male connector FMCN1567 datasheet specifications and outline drawing are shown in this PDF below. Our extensive offering of RF, microwave and millimeter wave connectors allows designers to configure and customize their signal connections however they like. From providing an I/O for a board design to creating a custom cable assembly configuration, Fairview Microwave has a connector solution to meet your needs. Fairview Microwave also has the expertise to build your custom cable assemblies for you and ship them same-day.

### Electrical Specifications

Description	Min	Typ	Max	Units
Frequency Range	DC		4	GHz
VSWR			1.3:1	
Operating Voltage (AC)			500	Vrms

### Mechanical Specifications

<b>Size</b>	
Length	1.13 in [28.7 mm]
Width/Dia.	0.571 in [14.50 mm]

### Material Specifications

Description	Material	Plating
Contact	Brass	Gold 30 µin minimum
Insulation	PTFE	
Body	Brass	Nickel 100 µin minimum
Coupling Nut	Brass	Nickel 100 µin minimum
Crimp Sleeve	Brass	Nickel

### Environmental Specifications

<b>Temperature</b>	
Operating Range	-65 to +165 deg C

**Compliance Certifications** (see [product page](#) for current document)

### Plotted and Other Data

Notes:



### Configuration:

- BNC Male Connector
- MIL-STD-348A
- 50 Ohms
- Straight Body Geometry
- RG55, RG141, RG142, RG223, RG400 Interface Type
- Crimp/Solder Attachment

### Features:

- Operating Frequency of 4 GHz Max.
- Good VSWR of 1.3:1
- Gold Plated Brass Contact
- 30 µin minimum contact plating

### Applications:

- General Purpose Test
- Custom Cable Assemblies

Fairview Microwave  
301 Leora Ln., Suite 100  
Lewisville, TX 75056  
Tel: 1-800-715-4396 / (972) 649-6678  
Fax: (972) 649-6689  
[www.fairviewmicrowave.com](http://www.fairviewmicrowave.com)  
[sales@fairviewmicrowave.com](mailto:sales@fairviewmicrowave.com)

BNC Male Connector Crimp/Solder Attachment for RG55, RG141, RG142, RG223, RG400 Cable from Fairview Microwave is in-stock and available to ship same-day. All of our RF/microwave products are available off-the-shelf from our ISO 9001:2008 certified facilities in Allen, Texas. Fairview Microwave is RF on-demand.

For additional information on this product, please click the following link: [BNC Male Connector Crimp/Solder Attachment for RG55, RG141, RG142, RG223, RG400 Cable FMCN1567](#)

URL: <https://www.fairviewmicrowave.com/bnc-male-rg55-rg141-rg142-rg223-rg400-connector-fmcn1567-p.aspx>

The information contained in this document is accurate to the best of our knowledge and representative of the part described herein. It may be necessary to make modifications to the part and/or the documentation of the part, in order to implement improvements. Fairview Microwave reserves the right to make such changes as required. Unless otherwise stated, all specifications are nominal. Fairview Microwave does not make any representation or warranty regarding the suitability of the part described herein for any particular purpose, and Fairview Microwave does not assume any liability arising out of the use of any part or documentation.



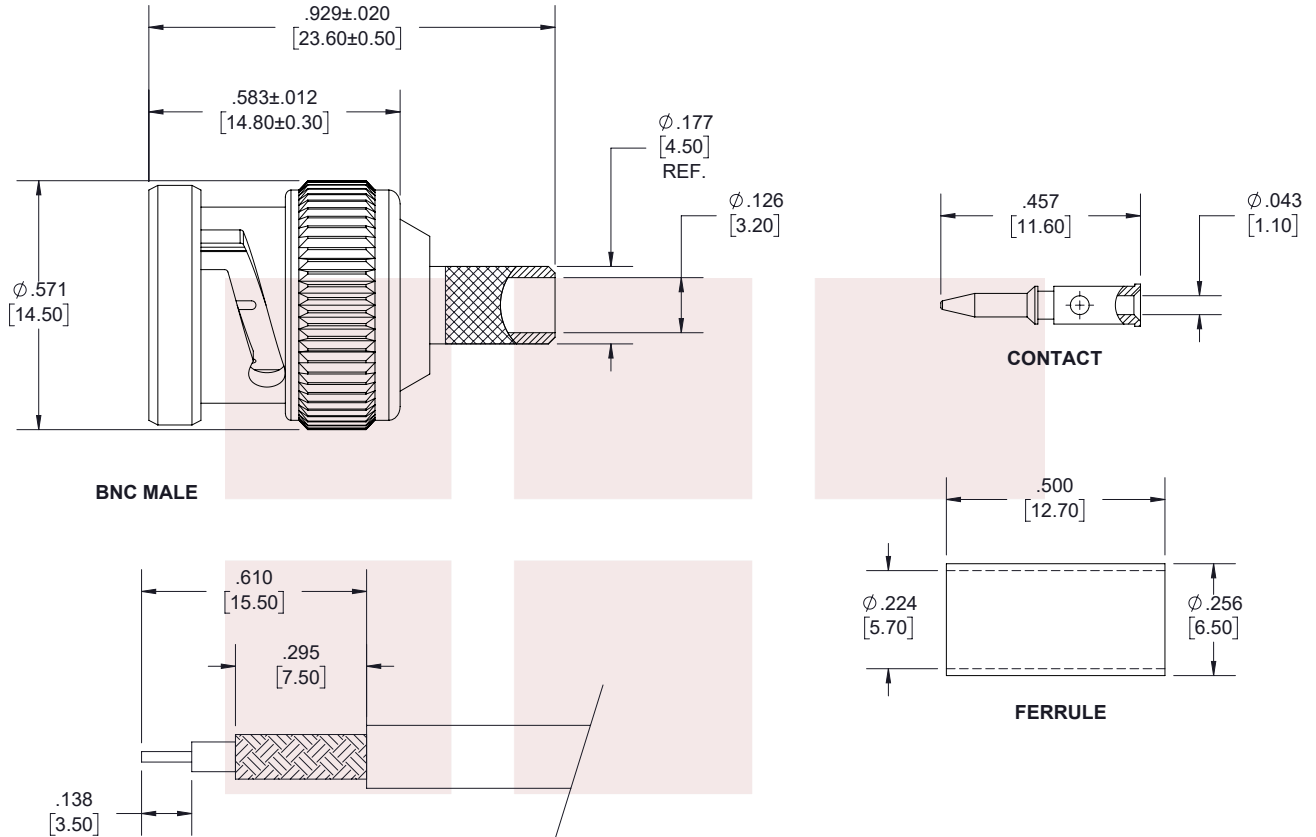

**STRIPPING DIMENSIONS**

**NOTES:**

1. CABLE ATTACHMENT:
  - OUTER: CRIMP.
  - INNER: SOLDER/CRIMP.
2. CRIMP SIZE REQUIRED:
  - FERRULE: .221 [5.60] HEX. CRIMP TOOL.
  - CONTACT: .071 [1.80] HEX. CRIMP TOOL.

**STANDARD TOLERANCES**

- .X ±0.2
- .XX ±0.01
- .XXX ±0.005

\*STANDARD TOLERANCES APPLY ONLY TO DIMENSIONS IN INCHES

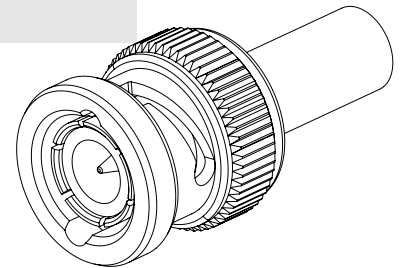

<p><b>Fairview Microwave</b> an INFINIT<sup>®</sup> brand</p>		<p>NOTES: 1. UNLESS OTHERWISE SPECIFIED ALL DIMENSIONS ARE NOMINAL. 2. ALL SPECIFICATIONS ARE SUBJECT TO CHANGE WITHOUT NOTICE AT ANY TIME. 3. DIMENSIONS ARE IN INCHES [mm].</p>						
<p>TITLE BNC Male Connector Crimp/Solder Attachment for RG55, RG141, RG142, RG223, RG400 Cable</p>		<p>DWG NO <b>FMCN1567</b></p>		<p>CAGE CODE <b>3FKR5</b></p>				
CAD FILE	06/17/19	SHEET	1 OF 1	SCALE	N/A	SIZE	A	7361