

BNC/M - N/F-BLKHD FLEXIBLE CABLES 6GHZ LMR240

SCB112558-XX

SPECIFICATIONS

CABLE ASSEMBLY:

VSWR:1.2:1 @ < 6GHZ TYPICAL

RAW CABLE: LMR240

TYPICAL LOSS (EXCLUDING CONNECTORS)

@ 100MHZ: 0.024 DB/FT

@ 1GHZ: 0.081 DB/FT

@ 2GHZ: 0.116 DB/FT

@ 3GHZ: 0.143 DB/FT

CONNECTORS:

BNC: BRASS

CONTACTS Au PLATING

INTERFACE: MIL-STD-348A

OP TEMP: -55-110°C

ROHS COMPLIANT

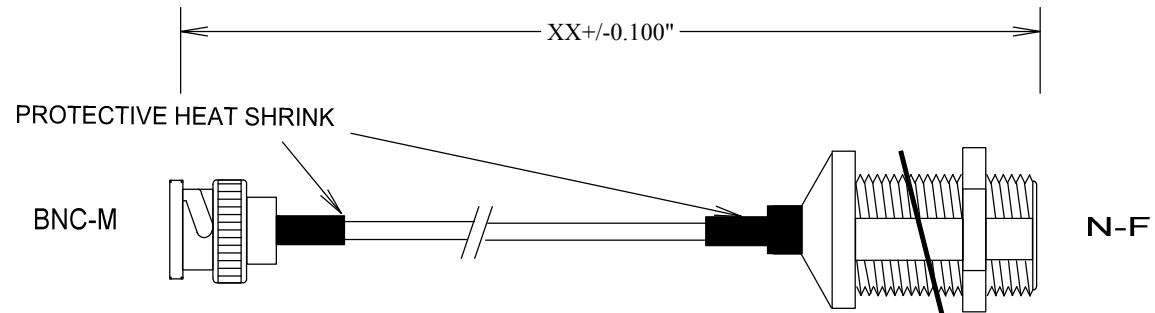

MEASUREMENTS BELOW ARE TYPICAL

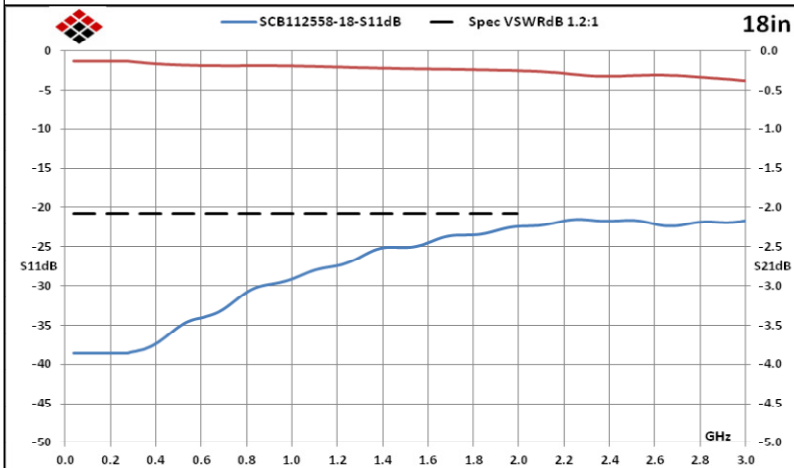

ALL DIMENSIONS IN inches(MM) Typical

FAIRVIEW MICROWAVE INC.

ALLEN, TX 75013 WWW.FAIRVIEWMICROWAVE.COM

TITLE

BNC/M - N/F-BLKHD FLEXIBLE CABLES
6GHZ LMR240

SIZE	CAGE CODE	DWG NO	REV
A	3FKR5	SCB112558-XX	--
SCALE			SHEET