

4 Cellular, 1 GPS Combination Antenna  
4 N Type, 1 TNC Connector White



**FMANOM1133**

**Features**

- 4 x Cellular 4G/5G N Male
- 1 x GPS L1 / G1 TNC Male
- MIMO Capable
- 17 ft Cable Leads
- Indoor/Outdoor IP69K Rated
- UV Stabilized White ABS

**Applications**

- Public Safety
- Emergency Services
- Mobile Base Stations
- Autonomous Vehicles
- Fleet Management
- Smart Cities
- Smart Utilities
- Industrial IoT

**Description**

The Fairview Microwave FMANOM1133 is a 5-in-1 combination antenna designed for public safety, emergency services, mobile base stations, autonomous vehicles, fleet management, smart cities, smart utilities, or industrial IoT applications. This vertically polarized omnidirectional antenna has N male and TNC male connectors with 17 feet cable leads. Our high-quality mobile antenna with 5 ports has a typical input VSWR of 2:1.

The IoT combination antenna from Fairview Microwave has an overall length of 7 inches, width of 7 inches, and weight of 4 lbs. This FMANOM1133 mobile antenna is IP69K-rated and has a black-colored radome made of UV-stabilized ABS. The 4 cellular, 1 GPS combination antenna has an impedance of 50 Ohms and a maximum input power of 10 Watts.

Our vertically polarized mobile antenna can operate at temperatures ranging from -40 to 70 degrees C. This MIMO-capable IoT antenna features four 4G/5G, and one L1/G1 GPS band elements in one radome. Emergency services, first responders, and fleets can rely on our 5-in-1 combination antenna to maintain a secure link between vehicles and dispatch centers.

**Configuration**

Design	Mobile
Radiation Pattern	Omni Directional
Polarization	Vertical
Connector Type	N Male
Interface 2	TNC Male
Number of Ports	5

**Electrical Specifications**

Description	Minimum	Typical	Maximum	Units
Input VSWR		2:1		
Impedance		50		Ohms
Input Power			10	Watts

4 Cellular, 1 GPS Combination Antenna  
4 N Type, 1 TNC Connector White



## FMANOM1133

Cellular Specifications					
Frequency Range	617 - 960	1690 - 2700	3300 - 4200	4900 - 6000	MHz
Peak Gain	4	6	7	8	dBi
Port Count	4				
Cable Type	RG58				
Cable Length	17 [5] ft [m]				
Connector Type	N Male				
GPS Specifications					
Frequency Range	1562 - 1612				MHz
VSWR	<2.0:1 ± 4 MHz				
LNA Gain	26 dB				
Out of band rejection	>40 dB (@ > +/- 100 MHz)				
Typical Noise Figure	≤ 2.7 dB				
Notch Filter rejection @787MHz	24 dB				
Operating Voltage	3 - 5 VDC				
Typical Current	15 mA				
Cable Type / Length	RG174 / 17 ft [5 m]				
Connector Type	TNC Male				

### Mechanical Specifications

Radome Material	UV Stabilized ABS
<b>Size</b>	
Length	7 in [177.8 mm]
Width	7 in [177.8 mm]
Height	3.15 in [80.01 mm]
Weight	4 lbs [1.81 kg]

### Environmental Specifications

<b>Temperature</b>	
Operating Range	-40 to +70 deg C
Ingress Protection	IP69K

**Compliance Certifications** (see [product page](#) for current document)

### Plotted and Other Data

Notes:

4 Cellular, 1 GPS Combination Antenna  
4 N Type, 1 TNC Connector White



## FMANOM1133

### Typical Radiation Pattern

### Appendix

**Electrical Downtilt:** Angle in the antenna's elevation pattern in which the maximum gain occurs.

**Gain:** Antenna's average gain.

**Front to Back Ratio @ 180°±30°:** Average difference between the antenna's maximum gain and the maximum gain in the antenna's back lobe over ±30° angles.

**Cross-polarization Ratio (dB):** Typical difference between the co-polarization and cross-polarization gain across the sector's 3 dB Beam Width.

Dedicated to serving the needs of the Wireless Internet Service Provider (WISP) market, KP Performance Antennas offers purpose built products that reliably perform in the field. KP Performance Antennas product line consists of Yagi, Grid, Omni, Dish and other style antennas that operate in the 900 MHz, 2.4 GHz, 3 GHz, and 5 GHz frequencies.

4 Cellular, 1 GPS Combination Antenna 4 N Type, 1 TNC Connector White from Fairview Microwave is in-stock and available to ship same-day. All of our RF/microwave products are available off-the-shelf from our ISO 9001:2008 certified facilities in Lewisville, Texas. Fairview Microwave is RF on-demand.

For additional information on this product, please click the following link: [4 Cellular, 1 GPS Combination Antenna 4 N Type, 1 TNC Connector White FMANOM1133](#)

URL: <https://www.fairviewmicrowave.com/product/antennas/dbi-band-mobile-antenna-tnc-connector-fmanom1133.html>

The information contained within this document is accurate to the best of our knowledge and representative of the part described herein. It may be necessary to make modifications to the part and/or the documentation of the part in order to implement improvements. Fairview Microwave reserves the right to make such changes as required. Unless otherwise stated, all specifications are nominal. Fairview Microwave does not make any representation or warranty regarding the suitability of the part described herein for any particular purpose, and Fairview Microwave does not assume liability arising out of the use of any part or document.

# FMANOM1133 CAD Drawing

4 Cellular, 1 GPS Combination Antenna 4 N Type, 1 TNC Connector White

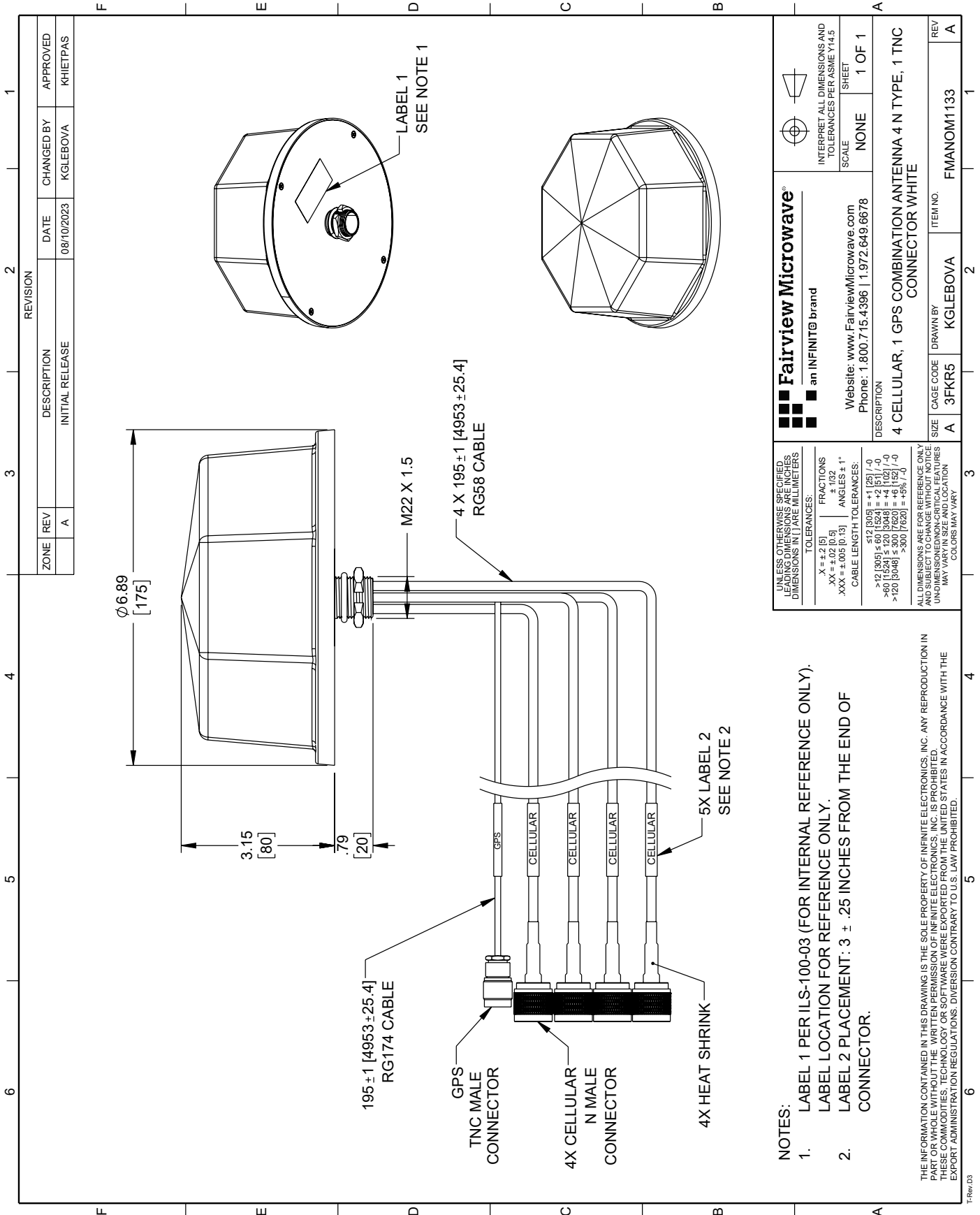

**NOTES:**

1. LABEL 1 PER ILS-100-03 (FOR INTERNAL REFERENCE ONLY). LABEL LOCATION FOR REFERENCE ONLY.
2. LABEL 2 PLACEMENT: 3 ± .25 INCHES FROM THE END OF CONNECTOR.