

4.4 GHz to 4.9 GHz, SMA, GaN Bi-Directional Amplifier, C-Band, 15W Psat, 45dB Tx Gain, 35% Efficiency, 2 microsec speed, Manual T/R Control

The FM15B5004 is a Class AB high power Bi-Directional Amplifier that operates in C-Band from 4400 MHz to 4900 MHz. This amplifier generates 15 Watts typical Psat (3W linear) RF output power to boost performance of datalinks and transmitters. The module utilizes the latest Gallium Nitride (GaN) semiconductor technology with 35% power efficiency. The package design features a small form factor that's ideal for size, weight, and power (SWaP) constrained applications used in broadband RF telemetry, tactical communication, electronic warfare, and unmanned aircraft and ground systems, as well as software defined radios. Impressive typical performance includes 32 dBm P1dB output power at 4% EVM, and -30 dBc ACPR @ 2W average power, with 45 dB of transmit gain, 10 dB of receive gain, 2 μ sec switching speed, and low harmonic suppression of -25 dBc. Additionally, with a nominal 0 dBm (1 mW) RF input power, the amplifier can provide 45 dB of gain for continuous wave (CW) and near-constant envelope waveforms. Operating voltage is +28 Vdc with 4.6A of DC current. Additional features include manual T/R control, single power supply, and overvoltage protection. For TTL logic on/off control, transmit mode uses 0V or ground and receive mode uses N/C or +5V. The rugged Mil-Grade assembly supports female SMA RF input/output connectors and a micro-D 9 pin socket command control connector with an accessory cable assembly included. The operating baseplate temperature range is -40°C to +85°C and the unit is guaranteed to withstand up to 95% relative humidity, altitude levels up to 30,000 ft, and random vibration and shock profiles (see chart below). Pasternack also offers an accessory Harmonic filter option, model FMHFL0001 that can be used at the output of the FM15B5004 bidirectional power amplifier. This lowpass RF filter covers 2.5 to 6 GHz and has low insertion loss with power handling up to 50W and specifically designed to reduce harmonics at the output of transmitters operating at up through C-Band and offers rejection levels of greater than 20 dB from 8 GHz to 10 GHz. The filter is offered in a miniature SMA connectorized package.

Electrical Specifications (TA = +25°C, DC Voltage = 28Volts DC Current = 4.6A)

Transmit

Description	Min	Typ	Max	Unit
Frequency Range	4.4		4.9	GHz
Psat Output Power*	15	16		Watts
Output at 1dB Compression Point		+33		dBm
Gain		45		dB
Gain Flatness		±5		dB
2nd Harmonics			-25	dBc
3rd Harmonics			-25	dBc
Operating DC Voltage	27	28	32	Volts
Current Draw		4.6		A
Quiescent Current (biased)		950		mA
Switching Time		2		uSec
3rd Order Distortion		-30		dBc
Efficiency		35		%
Output Mismatch VSWR			10:1	
Input VSWR		2:1		

*0 dBm Input Power



Features:

- Bi-Directional GaN High Power Amplifier
- 15W Psat (3W Liner) Output Power
- C Band Class AB Design
- Frequency Range: 4.4 GHz to 4.9 GHz
- 45 dB Transmit Gain
- 10 dB Receive Gain
- Manual T/R Control
- Switching Speed 2 usec
- PAE: 35%
- +5V TTL Logic Control
- Small Form Factor Rugged Mil-Grade Package
- 50 Ohm Design
- Female SMA RF Connectors
- +28Vdc @ 4.6A DC Current
- +5V TTL Logic Control
- -40°C to +85°C Operating Baseplate Temperature
- Output Harmonic Filter Accessory Option

Applications:

- Unmanned Aircraft (UAS) Group 2 &3
- Unmanned Ground Vehicles (UGV)
- RF Telemetry
- RF Communications Systems
- Software Defined Radios
- Data Links
- Transmitters
- Test & Measurement
- Telecom Infrastructure

Fairview Microwave
 301 Leora Ln., Suite 100
 Lewisville, TX 75056
 Tel: 1-800-715-4396 / (972) 649-6678
 Fax: (972) 649-6689
www.fairviewmicrowave.com
sales@fairviewmicrowave.com

Receive

Description	Min	Typ	Max	Unit
1 dB Compression Point		+18		dBm
Gain		10		dB
Gain Flatness		±1		dB
Noise Figure		3.5		dB
Current Draw		300		mA

Performance by Frequency
Transmit

Description	F1	F2	F3	Units
Frequency Condition	4.4	4.65	4.9	GHz
RF Output Power, Typ (P1dB)	33	32	30	dB
Small Signal Gain, Typ (@-30 dBm Input)	48	48	45	dBm

Protections

Parameter	Rating	Unit
Max Device Voltage	32	V
Max Device Current	7.0	A
Max RF Input Power @ ANT Port, $Z_L = 50 \Omega$	+5	dBm
Max RF Input Power @ XCVR Port, $Z_L = 50 \Omega$	+15	dBm
Max Operating Temperature (ambient)	55	°C
Max Operating Temperature (baseplate)	85	°C
Max Storage Temperature	100	°C



ESD Sensitive Material,
 Transport material in Approved
 ESD bags. Handle only in
 approved
 ESD Workstation.

Mechanical Specifications

Size

Length	5.5 in [139.7 mm]
Width	4.5 in [114.3 mm]
Height	0.71 in [18.03 mm]
Weight	0.67 lbs [303.91 g]
RF Connector (Input)	SMA Female
RF Connector (Output)	SMA Female
DC Connector	Micro-D, 9-Pin Socket

Environmental Specifications

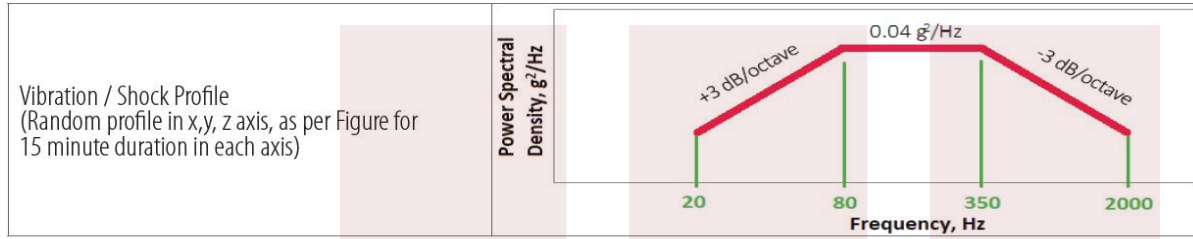

Temperature

Operating Range	-40 to +85 deg C
Storage Range	-55 to +100 deg C
Humidity	95%
Altitude	MIL-STD-810F Method 5004

Compliance Certifications (see [product page](#) for current document)

Plotted and Other Data

Notes:

- Values at +25 °C, sea level

Amplifier Power-up Precautions

- 1.) Confirm that proper ESD precautions and controls are always in place before handling any Amplifier module.
- 2.) Confirm adequate thermal management is in place to effectively dissipate heat away from the Amplifier package. The Amplifier operational baseplate temperature must be within the operational temperature range stated in the Amplifier datasheet. Depending on the design and thermal requirements, using a heatsink with cooling fan is always recommended for safe reliable operation. A heat sink without a cooling fan may also be used. Damage caused from overheating will void the warranty.
- 3.) Confirm adequate system grounding is established. The DC power supply and Amplifier must have a common ground in order to operate properly.
- 4.) Power Amplifiers may require additional DC Current when initially powered-up. Depending on the design, the input current draw could range from an additional 10% to 100% above the maximum rated DC current of the Amplifier. This varies based on product part number.
- 5.) Confirm the DC power supply, if limited, is set to allow for additional start-up current that's rated for the Power Amplifier.
- 6.) Confirm the system is designed and calibrated for 50 ohms. Any impedance mismatch may cause performance issues.
- 7.) Perform a CALIBRATION (if required) with the loads before connecting the Amplifier to the Network Analyzer to ensure proper performance.
- 8.) Use a fixed attenuator between the signal source and input port of the Amplifier to optimize the input VSWR match.
- 9.) Confirm the input power level at the input port of the amplifier does not exceed the maximum rated limit for input power (as stated in the Amplifier datasheet).
 P_{in} for Small Signal Gain = P1dB-SSG-10 dB
 P_{in} for P1dB = P1dB-SSG+1 dB
- 10.) Confirm the Network Analyzer is always connected to the Amplifier first before DC power is applied to the Amplifier.
- 11.) As long as the input and output ports of the amplifier are connected to a 50Ohm load and RF signal power is applied, the Amplifier can be powered up with DC voltage.
- 12.) Confirm the Amplifier output load is matched for a 50 Ohm impedance and will not exceed the maximum rated VSWR or Return Loss limit for the Amplifier. Exceeding the maximum rated VSWR or Return Loss limit will result in reflected signal power that could damage the Amplifier and void the warranty.
- 13.) **Power Amplifier connected to an Antenna for signal transmission** - It's strongly recommended to use a high power fixed attenuator pad or an Isolator between the output port of the Amplifier and input port to the antenna. Any reflected signal power due to impedance mismatch will likely damage the Amplifier and void the warranty.
- 14.) The attenuator or isolator used at the output port of the Amplifier must be rated to handle the output power level and operational frequency band of the amplifier.

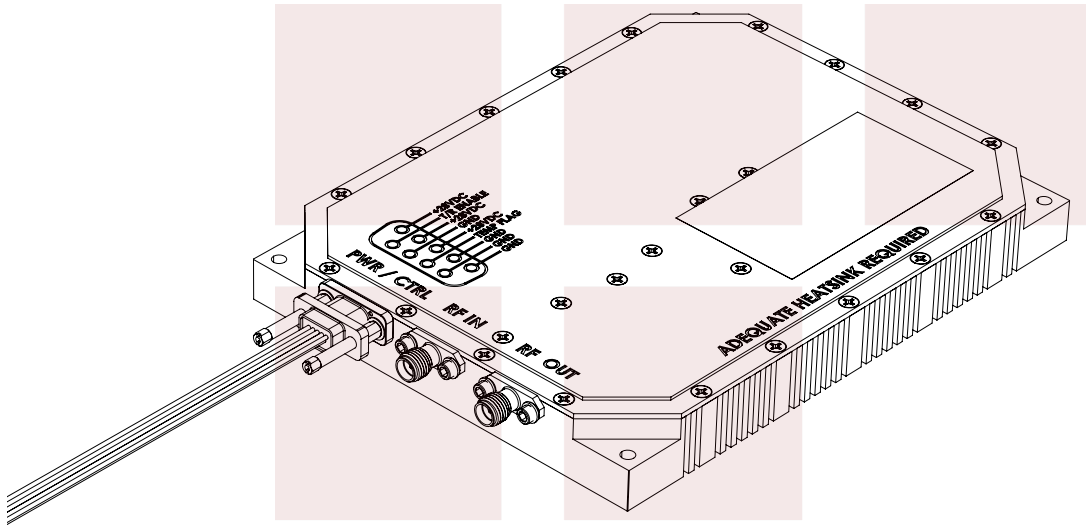
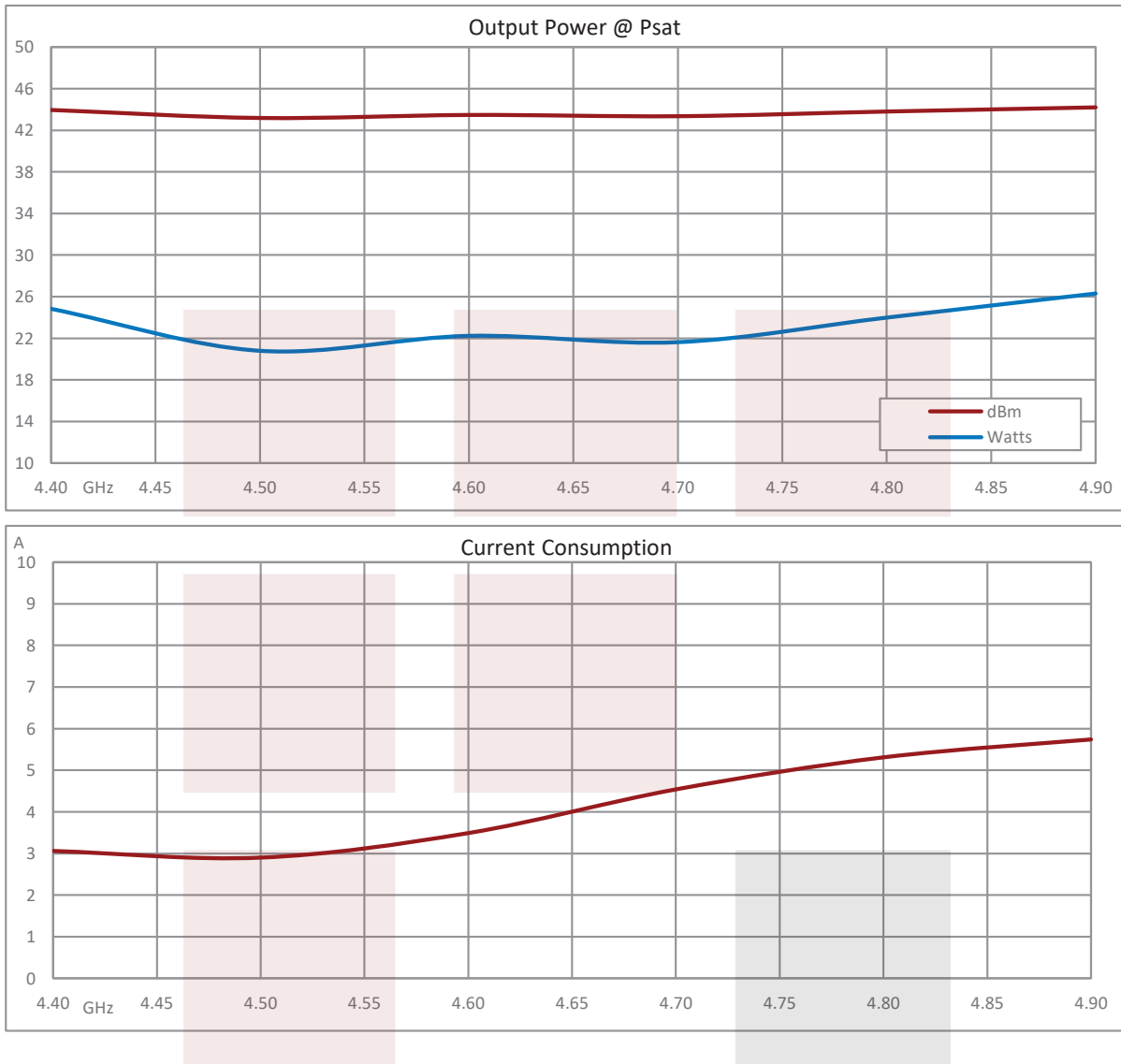
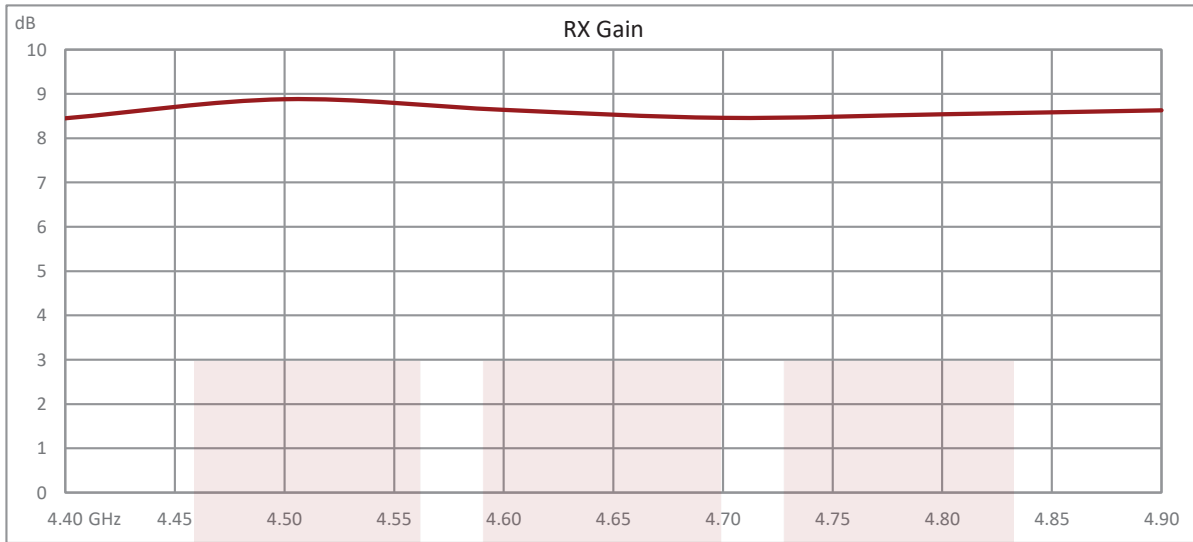

illustration of Amplifier & Interface Cable

Typical Performance Data





4.4 GHz to 4.9 GHz, SMA, GaN Bi-Directional Amplifier, C-Band, 15W Psat, 45dB Tx Gain, 35% Efficiency, 2 microsec speed, Manual T/R Control from Fairview Microwave is in-stock and available to ship same-day. All of our RF/microwave products are available off-the-shelf from our ISO 9001:2008 certified facilities in Lewisville, Texas. Fairview Microwave is RF on-demand.

For additional information on this product, please click the following link: [4.4 GHz to 4.9 GHz, SMA, GaN Bi-Directional Amplifier, C-Band, 15W Psat, 45dB Tx Gain, 35% Efficiency, 2 microsec speed, Manual T/R Control FM15B5004](https://www.fairviewmicrowave.com/high-power-bi-directional-amplifier-15-watts-4.9-ghz-sma-fm15b5004-p.aspx)

URL: <https://www.fairviewmicrowave.com/high-power-bi-directional-amplifier-15-watts-4.9-ghz-sma-fm15b5004-p.aspx>

The information contained in this document is accurate to the best of our knowledge and representative of the part described herein. It may be necessary to make modifications to the part and/or the documentation of the part, in order to implement improvements. Fairview Microwave reserves the right to make such changes as required. Unless otherwise stated, all specifications are nominal. Fairview Microwave does not make any representation or warranty regarding the suitability of the part described herein for any particular purpose, and Fairview Microwave does not assume any liability arising out of the use of any part or documentation.

REVISIONS			
REV.	DESCRIPTION	DATE	APPROVED
A	INITIAL RELEASE	6/12/2020	T.GALLA

Dimensions:
 Top view: .68 [17.3], .49 [12.5], 5.50 [139.7], 5.19 [131.9], .15 [3.9], 3.94 [100.2], 4.25 [108.0]
 Side view: .511 [12.98] TYP, 1.24 [31.6], 2.13 [54.0], 3.01 [76.4]
 Detail A: PIN 9, PIN 5, PIN 6, PIN 1

Labels:
 MICRO-D 9-PIN SOCKET
 2X SMA FEMALE (SEE PINOUT TABLE)
 PWR / CTRL
 RF IN
 RF OUT
 +28VDC
 T/R ENABLE
 +5VDC
 GND
 +28VDC
 TEMP FLAG
 GND
 GND
 GND
 ADEQUATE HEATSINK REQUIRED

Pinout Table:

Pinout		
Pin #	I/O	Function
1,2,6,8	I	GND
3,4,5	I	DC Power (+28VDC)
7	0	Over Temperature Flag 0V = Temperature Fault +5V = No Fault
9	I	T/R Control (5V Logic) Manual Mode 0V or GND = TX N/C or +5V = RX

Label:

Fairview Microwave
 an INFINIT[®] brand
 www.fairviewmicrowave.com
FM15B5004
 V002162YYYYMMDDXXXX

THESE COMMODITIES, TECHNOLOGY OR SOFTWARE WERE EXPORTED FROM THE UNITED STATES IN ACCORDANCE WITH THE EXPORT ADMINISTRATION REGULATIONS. DIVERSION CONTRARY TO U.S. LAW PROHIBITED.

<p>Fairview Microwave an INFINIT[®] brand</p> <p>TITLE</p> <p>4.4 GHz to 4.9 GHz, SMA, GaN Bi-Directional Amplifier, C-Band, 15W Psat, 45dB Tx Gain, 35% Efficiency, 2 microsec speed, Manual T/R Control</p>	<p>UNLESS OTHERWISE SPECIFIED LEADING DIMENSIONS ARE INCHES DIMENSIONS IN [] ARE MILLIMETERS</p> <p>TOLERANCES: CABLE LENGTH (L) TOLERANCES:</p> <p style="text-align: center;">L ≤ 12 [305] = +1 [25] / -0</p> <p style="text-align: center;">12 [305] < L ≤ 60 [1524] = +2 [51] / -0</p> <p style="text-align: center;">60 [1524] < L ≤ 120 [3048] = +4 [102] / -0</p> <p style="text-align: center;">120 [3048] < L ≤ 300 [7620] = +6 [152] / -0</p> <p style="text-align: center;">300 [7620] < L = +5%L / -0</p>	<p>THIRD-ANGLE PROJECTION</p> <p>THE INFORMATION AND DESIGN IN THIS DOCUMENT IS THE PROPERTY OF FAIRVIEW MICROWAVE CORPORATION. ALL RIGHTS RESERVED.</p>
	<p>ALL DIMENSIONS SHOWN ARE FOR REFERENCE ONLY.</p>	<p>SHEET 1 OF 3</p> <p>SCALE N/A</p>
<p>SIZE A CAGE CODE 3FKR5 DRAWN BY K.DANG ITEM NO. FM15B5004 REV. A</p>		

INTERFACE CABLE

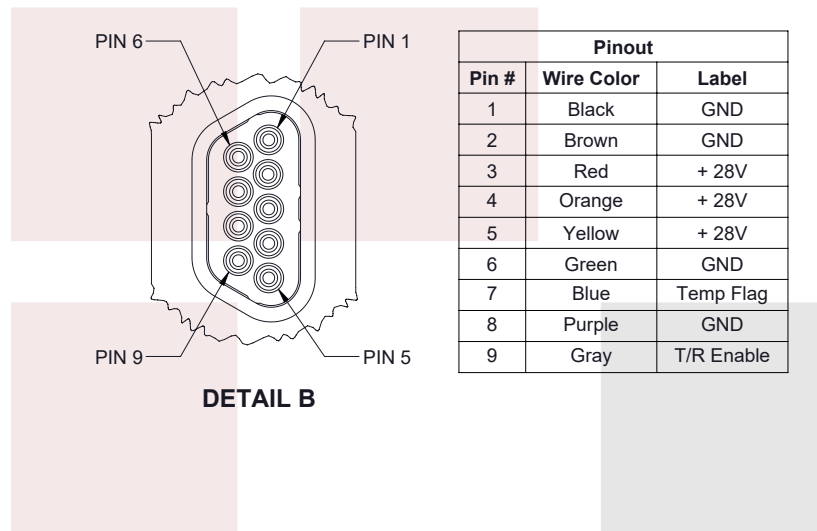
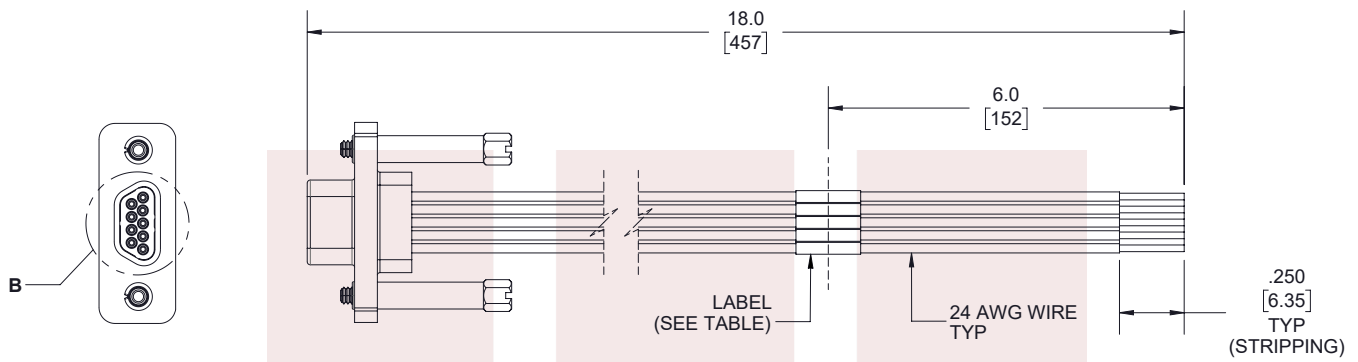

Pinout		
Pin #	Wire Color	Label
1	Black	GND
2	Brown	GND
3	Red	+ 28V
4	Orange	+ 28V
5	Yellow	+ 28V
6	Green	GND
7	Blue	Temp Flag
8	Purple	GND
9	Gray	T/R Enable

THESE COMMODITIES, TECHNOLOGY OR SOFTWARE WERE EXPORTED FROM THE UNITED STATES IN ACCORDANCE WITH THE EXPORT ADMINISTRATION REGULATIONS. DIVERSION CONTRARY TO U.S. LAW PROHIBITED.

TITLE
4.4 GHz to 4.9 GHz, SMA, GaN Bi-Directional Amplifier, C-Band, 15W Psat, 45dB Tx Gain, 35% Efficiency, 2 microsec speed, Manual T/R Control

UNLESS OTHERWISE SPECIFIED LEADING DIMENSIONS ARE INCHES
DIMENSIONS IN [] ARE MILLIMETERS

TOLERANCES: CABLE LENGTH (L) TOLERANCES:

.X = ±.2 [5.08]	FRACTIONS	L ≤ 12 [305] = +1 [25] / -0
.XX = ±.02 [.51]	± 1/32	12 [305] < L ≤ 60 [1524] = +2 [51] / -0
.XXX = ±.005 [.13]	ANGLES ± 1°	60 [1524] < L ≤ 120 [3048] = +4 [102] / -0
		120 [3048] < L ≤ 300 [7620] = +6 [152] / -0
		300 [7620] < L = +5%L / -0

THIRD-ANGLE PROJECTION

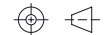

THE INFORMATION AND DESIGN IN THIS DOCUMENT IS THE PROPERTY OF FAIRVIEW MICROWAVE CORPORATION. ALL RIGHTS RESERVED.

SHEET 2 OF 3

ALL DIMENSIONS SHOWN ARE FOR REFERENCE ONLY.

SCALE N/A

SIZE A	CAGE CODE 3FKR5	DRAWN BY K.DANG	ITEM NO. FM15B5004	REV A
--------	-----------------	-----------------	--------------------	-------

T-Rev.D