

SMA MALE

SMA FEMALE

**LABEL**

**Fairview Microwave**  
 RF COMPONENTS ON DEMAND *Done!*  
 www.fairviewmicrowave.com  
**SA18E-11**  
 YWWW

**STANDARD TOLERANCES**

- .X ±0.2
- .XX ±0.01
- .XXX ±0.005

\*STANDARD TOLERANCES APPLY ONLY TO DIMENSIONS IN INCHES

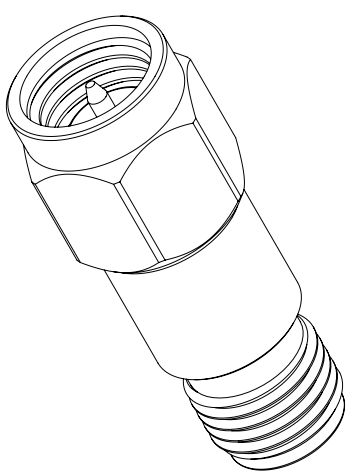

**Fairview Microwave**  
 RF COMPONENTS ON DEMAND. *Done!*

NOTES:  
 1. UNLESS OTHERWISE SPECIFIED ALL DIMENSIONS ARE NOMINAL.  
 2. ALL SPECIFICATIONS ARE SUBJECT TO CHANGE WITHOUT NOTICE AT ANY TIME.  
 3. DIMENSIONS ARE IN INCHES [mm].

TITLE		DWG NO		CAGE CODE	
		SA18E-11		3FKR5	
CAD FILE	12/18/18	SHEET	1 OF 1	SCALE	N/A
				SIZE	A
					7361