

REVISIONS			
REV.	DESCRIPTION	DATE	APPROVED
A	INITIAL RELEASE	06/08/2021	KHIETPAS

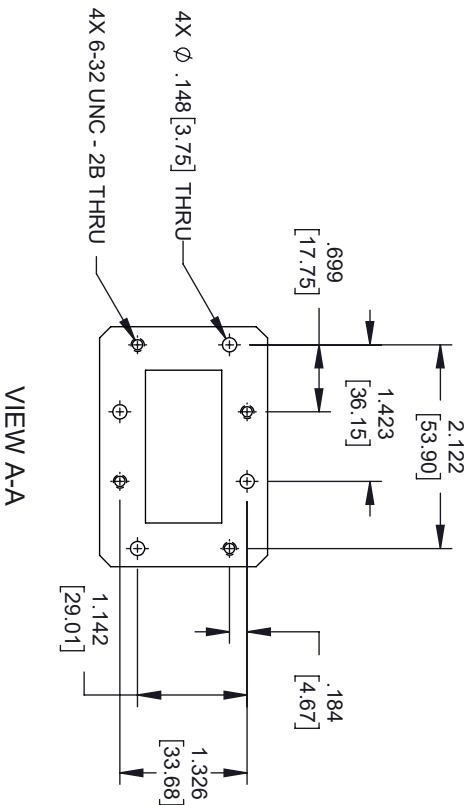

- NOTES:  
 1. LABEL PER ILS-100-03 (FOR INTERNAL REFERENCE ONLY)  
 LABEL LOCATION FOR REFERENCE ONLY

THESE COMMODITIES, TECHNOLOGY OR SOFTWARE WERE EXPORTED FROM THE UNITED STATES IN ACCORDANCE WITH THE EXPORT ADMINISTRATION REGULATIONS, DIVERSION CONTRARY TO U.S. LAW PROHIBITED.

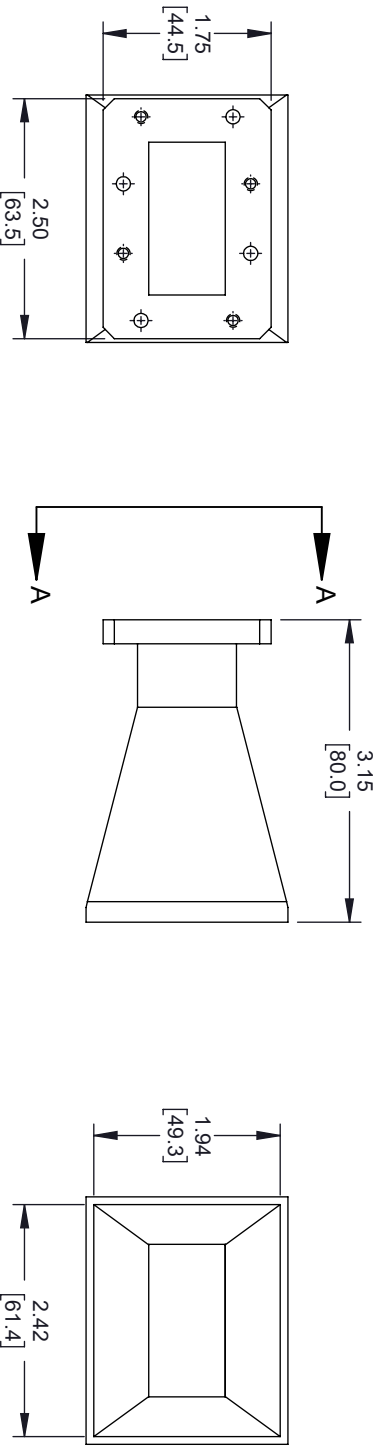
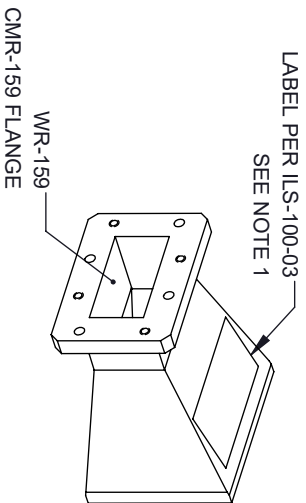

UNLESS OTHERWISE SPECIFIED LEADING DIMENSIONS ARE INCHES  
 DIMENSIONS IN [ ] ARE MILLIMETERS

TOLERANCES:

CABLE LENGTH (L) TOLERANCES:



THIRD-ANGLE PROJECTION

X = ±.2 [5.08] FRACTIONS  
 XX = ±.02 [.51] ±.1/32  
 XXX = ±.005 [.13] ANGLES ± 1°

L ± 1/2 (806) = +1 [25] / -0  
 12 (305) < L ≤ 60 (1524) = +2 [51] / -0  
 60 (1524) < L ≤ 120 (3048) = +4 [102] / -0  
 120 (3048) < L ≤ 300 (7620) = +6 [152] / -0  
 300 (7620) < L = +5% / -0

THE INFORMATION AND DESIGN IN THIS DOCUMENT IS THE PROPERTY OF FAIRVIEW MICROWAVE CORPORATION. ALL RIGHTS RESERVED.

SHEET 1 OF 1

ALL DIMENSIONS SHOWN ARE FOR REFERENCE ONLY.

SCALE

N/A

SIZE	DWG CODE	DRAWN BY	ITEM NO.	REV
A	3FKRS	DZINN	FMWAN159-10	A