

6

5

4

3

2

1

REVISION					
ZONE	REV	DESCRIPTION	DATE	CHANGED BY	APPROVED
	A	INITIAL RELEASE	02/06/2025	KGLEBOVA	AGANWANI



7X SOLDER TERMINALS,
SOLDER WIRE USING SN96,
MAXIMUM TEMP 250 °C FOR
NO MORE THAN 5 SEC.

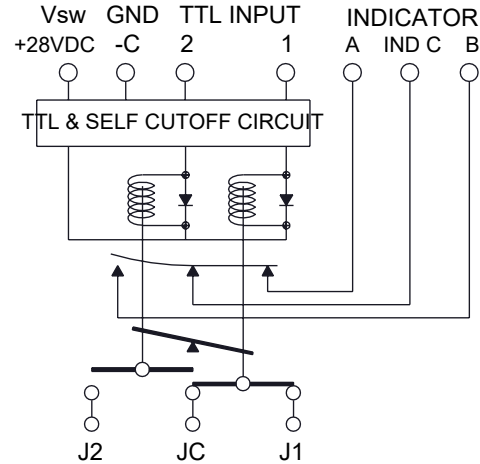

SCHEMATIC

F
E
D
C
B
A

F
E
D
C
B
A

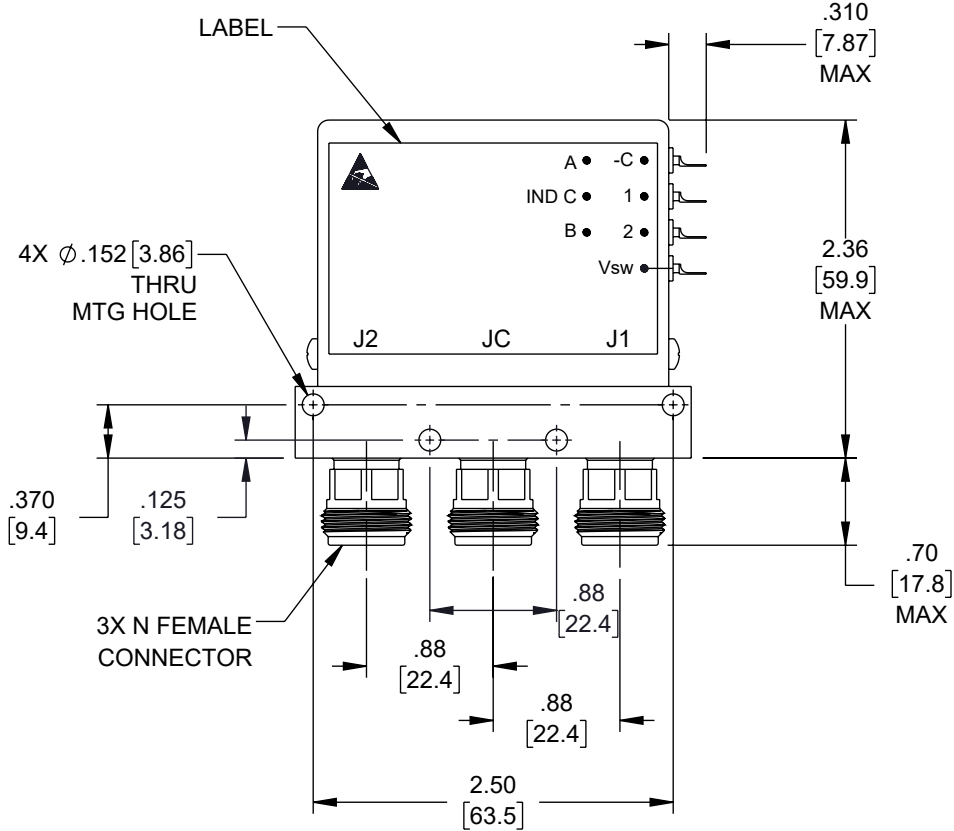

3X N FEMALE
CONNECTOR

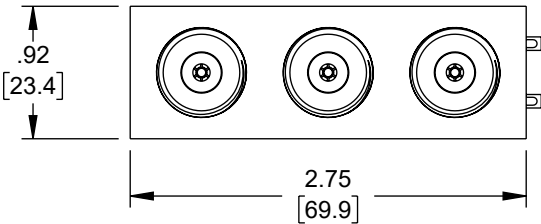

OPERATIONAL LOGIC TABLE					
TERMINALS		RF PORTS		INDICATOR	
2	0	J1	J2	A-IND C	B-IND C
2	0	NO CHANGE	NO CHANGE	NO CHANGE	NO CHANGE
0	1	OFF	ON	OFF	ON
1	0	ON	OFF	ON	OFF
1	1	FORBIDDEN	FORBIDDEN	FORBIDDEN	FORBIDDEN

UNLESS OTHERWISE SPECIFIED
LEADING DIMENSIONS ARE INCHES
DIMENSIONS IN [] ARE MILLIMETERS

TOLERANCES:
X = ±.2 [5] | FRACTIONS ± 1/32
XX = ±.02 [0.5] | ANGLES ± 1°
.XXX = ±.005 [0.13]

CABLE LENGTH TOLERANCES:
≤12 [305] = +1 [25] / -0
>12 [305] ≤ 60 [1524] = +2 [51] / -0
>60 [1524] ≤ 120 [3048] = +4 [102] / -0
>120 [3048] ≤ 300 [7620] = +6 [152] / -0
>300 [7620] = +5% / -0

ALL DIMENSIONS ARE FOR REFERENCE ONLY
AND SUBJECT TO CHANGE WITHOUT NOTICE
UN-DIMENSIONED/NON-CRITICAL FEATURES
MAY VARY IN SIZE AND LOCATION
COLORS MAY VARY



Website: www.FairviewMicrowave.com
Phone: 1.800.715.4396 | 1.972.649.6678

INTERPRET ALL DIMENSIONS AND TOLERANCES PER ASME Y14.5

SCALE	SHEET
NONE	1 OF 1

DESCRIPTION
**SPDT, LATCHING SELF CUT-OFF, DC TO 18 GHZ
ELECTROMECHANICAL RELAY SWITCH, INDICATORS, 28V, TTL,
DIODES, SOLDER TERMINAL, N**

SIZE	CAGE CODE	DRAWN BY	ITEM NO.	REV
A	3FKR5	KGLEBOVA	FMSW6595	A

THE INFORMATION CONTAINED IN THIS DRAWING IS THE SOLE PROPERTY OF INFINITE ELECTRONICS, INC. ANY REPRODUCTION IN PART OR WHOLE WITHOUT THE WRITTEN PERMISSION OF INFINITE ELECTRONICS, INC. IS PROHIBITED. THESE COMMODITIES, TECHNOLOGY OR SOFTWARE WERE EXPORTED FROM THE UNITED STATES IN ACCORDANCE WITH THE EXPORT ADMINISTRATION REGULATIONS. DIVERSION CONTRARY TO U.S. LAW PROHIBITED.

6

5

4

3

2

1