

REVISIONS			
REV.	DESCRIPTION	DATE	APPROVED
A	INITIAL RELEASE	05/19/2022	T.GALLA

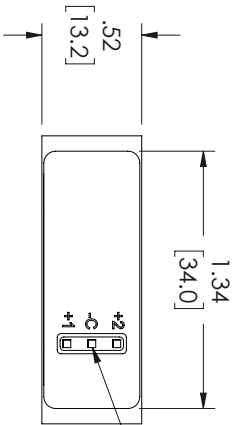

3X SOLDER TERMINALS
SOLDER WIRE USING SN63,
MAXIMUM TEMP 210 °C FOR
NO MORE THAN 5 SEC.

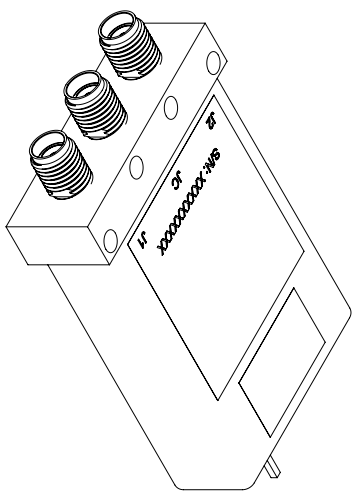
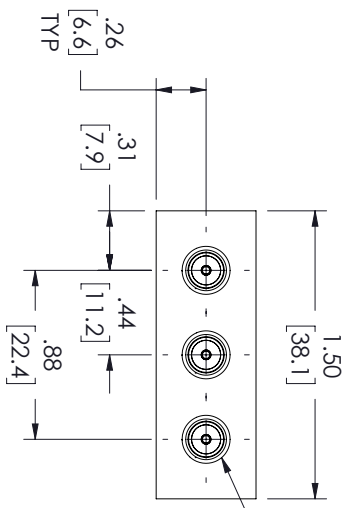
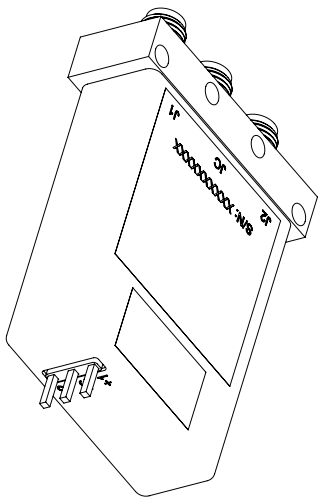
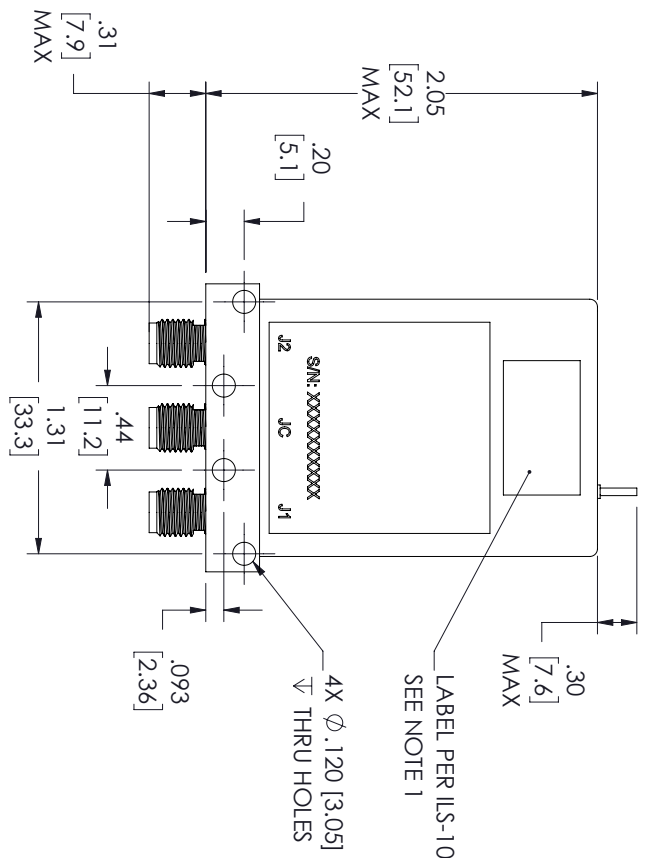

- NOTES:
- LABEL PER ILS-100-02. FOR INTERNAL REFERENCE ONLY.
LABEL LOCATION FOR REFERENCE ONLY.

THESE COMMODITIES, TECHNOLOGY OR SOFTWARE WERE EXPORTED FROM THE UNITED STATES IN ACCORDANCE WITH THE EXPORT ADMINISTRATION REGULATIONS, DIVERSION CONTRARY TO U.S. LAW PROHIBITED.



UNLESS OTHERWISE SPECIFIED LEADING DIMENSIONS ARE INCHES		THIRD-ANGLE PROJECTION	
DIMENSIONS IN [] ARE MILLIMETERS			
TOLERANCES:		THE INFORMATION AND DESIGN IN THIS DOCUMENT IS THE PROPERTY OF FAIRVIEW MICROWAVE CORPORATION. ALL RIGHTS RESERVED.	
CABLE LENGTH (L) TOLERANCES:		SCALE	
X = ±.2 [5.08]	FRACTIONS ± 1/32	L ≤ 12 [305] = +1 [25] / -0	1 OF 2
XX = ±.02 [51]	± 1/32	12 [305] < L ≤ 60 [1524] = +2 [51] / -0	
XXX = ±.005 [13]	ANGLES ± 1°	60 [1524] < L ≤ 120 [3048] = +4 [102] / -0	
		120 [3048] < L ≤ 300 [7620] = +6 [152] / -0	
		300 [7620] < L = +5% / -0	

ALL DIMENSIONS SHOWN ARE FOR REFERENCE ONLY.			
SIZE	GAGE CODE	DRAWN BY	ITEM NO.
A	3FKRS	KGLEBOVA	FMSW6477
			REV
			A