

6

5

4

3

2

1

REVISION					
ZONE	REV	DESCRIPTION	DATE	CHANGED BY	APPROVED
	B	ECO-14049	12/12/2024	KDANG	SRAUTUS

PARTS SUPPLIED

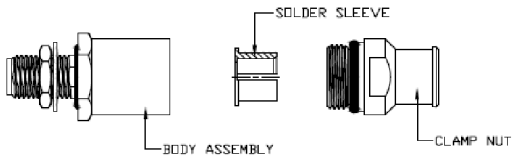

CONNECTOR COMPENSATIONS

THE CONNECTOR ADDS .585 FROM THE TIP OF THE CENTER CONDUCTOR TO THE END OF THE CONNECTOR AND .510 FROM THE TIP OF THE CENTER CONDUCTOR TO THE REF. PLANE.

STEP 1: CABLE PREPARATION

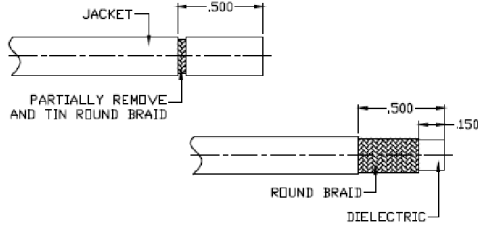

TRIM THE CABLE JACKET TO THE DIMENSION SHOWN AND PARTIALLY REMOVE. DIP THE ROUND BRAID IN SN-96 SOLDER PLOT (DO NOT USE FLUX OR ALCOHOL). REMOVE THE STRIPPED JACKET FROM THE BRAIDS. TRIM THE FLAT BRAIDS TO THE DIELECTRIC TO THE DIMENSIONS SHOWN.

STEP 2: SOLDER SLEEVE ATTACHMENT

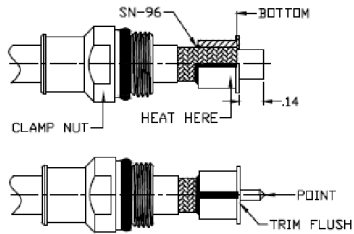

INSTALL THE SHRINK TUBING AND REAR NUT ONTO THE PREPARED CABLE. RE-FORM THE END OF THE CABLE AND GENTLY SLIDE THE SOLDER SLEEVE ONTO THE CABLE BRAID. SOLDER INTO POSITION USING SN-96 (DO NOT USE FLUX). TRIM CABLE DIELECTRIC FLUSH TO EXPOSE THE CENTER CONDUCTOR BEING CAREFUL NOT TO NICK THE CENTER CONDUCTOR. POINT THE CENTER CONDUCTOR.

STEP 4: CONNECTOR ASSEMBLY

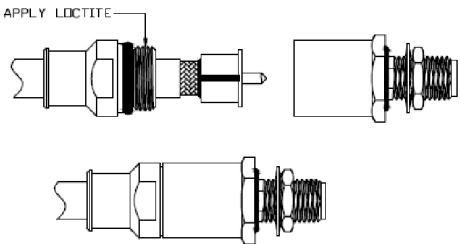

INSTALL THE PREPARED CABLE INTO THE BODY ASSEMBLY. APPLY THREAD LOCKER AND THREAD THE CLAMP NUT INTO THE BODY ASSEMBLY FINGER TIGHT. TORQUE TO 30 - 35 INCH POUNDS USING $\frac{3}{8}$ " & $\frac{1}{2}$ " WRENCHES.

STEP 5: GAGE & INSPECT

SMA FP	SMA FD
.000/- .010	.000/- .010

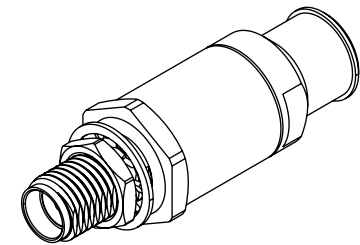
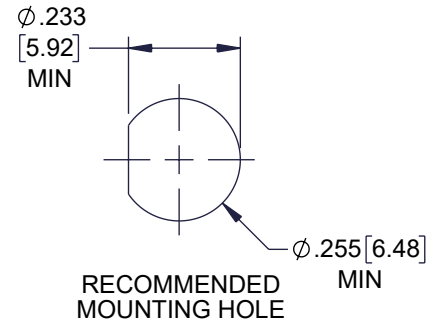
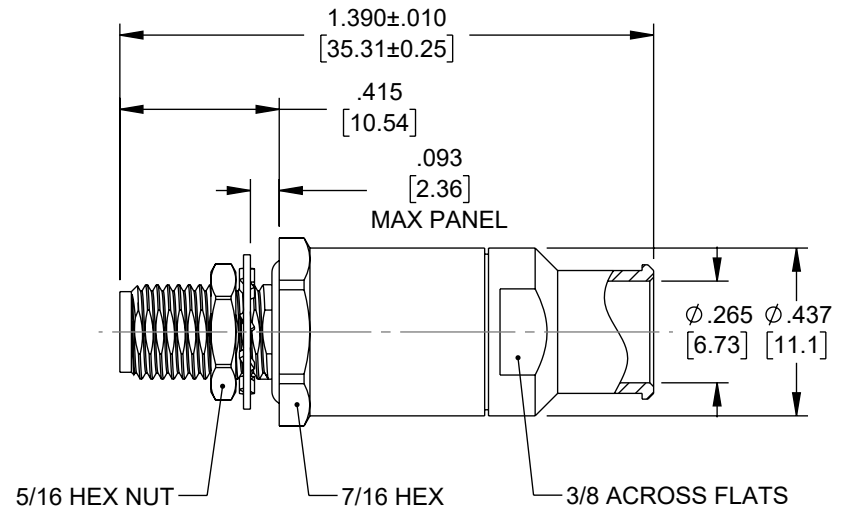

THE INFORMATION CONTAINED IN THIS DRAWING IS THE SOLE PROPERTY OF INFINITE ELECTRONICS, INC. ANY REPRODUCTION IN PART OR WHOLE WITHOUT THE WRITTEN PERMISSION OF INFINITE ELECTRONICS, INC. IS PROHIBITED. THESE COMMODITIES, TECHNOLOGY OR SOFTWARE WERE EXPORTED FROM THE UNITED STATES IN ACCORDANCE WITH THE EXPORT ADMINISTRATION REGULATIONS. DIVERSION CONTRARY TO U.S. LAW PROHIBITED.

UNLESS OTHERWISE SPECIFIED LEADING DIMENSIONS ARE INCHES DIMENSIONS IN [] ARE MILLIMETERS

TOLERANCES:

X = ±.2 [5]	FRACTIONS ± 1/32
XX = ±.02 [0.5]	ANGLES ± 1°
.XXX = ±.005 [0.13]	

CABLE LENGTH TOLERANCES:

≤12 [305]	= +1 [25] / -0
>12 [305] ≤ 60 [1524]	= +2 [51] / -0
>60 [1524] ≤ 120 [3048]	= +4 [102] / -0
>120 [3048] ≤ 300 [7620]	= +6 [152] / -0
>300 [7620]	= +5% / -0

ALL DIMENSIONS ARE FOR REFERENCE ONLY AND SUBJECT TO CHANGE WITHOUT NOTICE UN-DIMENSIONED/NON-CRITICAL FEATURES MAY VARY IN SIZE AND LOCATION COLORS MAY VARY



Website: www.FairviewMicrowave.com
Phone: 1.800.715.4396 | 1.972.649.6678

INTERPRET ALL DIMENSIONS AND TOLERANCES PER ASME Y14.5

SCALE	SHEET
NONE	1 OF 1

DESCRIPTION
SMA FEMALE BULKHEAD SPACE CONNECTOR CLAMP/SOLDER ATTACHMENT FOR FM-R200LL

SIZE	CAGE CODE	DRAWN BY	ITEM NO.	REV
A	3FKR5	AKRESOWSKI	FMCN5142	B

6

5

4

3

2

1