

QMA/PLUG-N FEMALE ADAPTER

SM5574

SPECIFICATIONS

ELECTRICAL
 50 OHMS
 FREQUENCY: 0-6 GHZ
 VSWR 1.15:1 MAX @ 6GHZ

MECHANICAL
 BODY: BRASS & PHOSPHOR BRONZE
 CONTACTS: BeCu
 PLATING CONTACTS: Au 30μ"
 INSULATOR: TEFLON
 INTERFACE: MIL-STD-348A

ROHS COMPLIANT

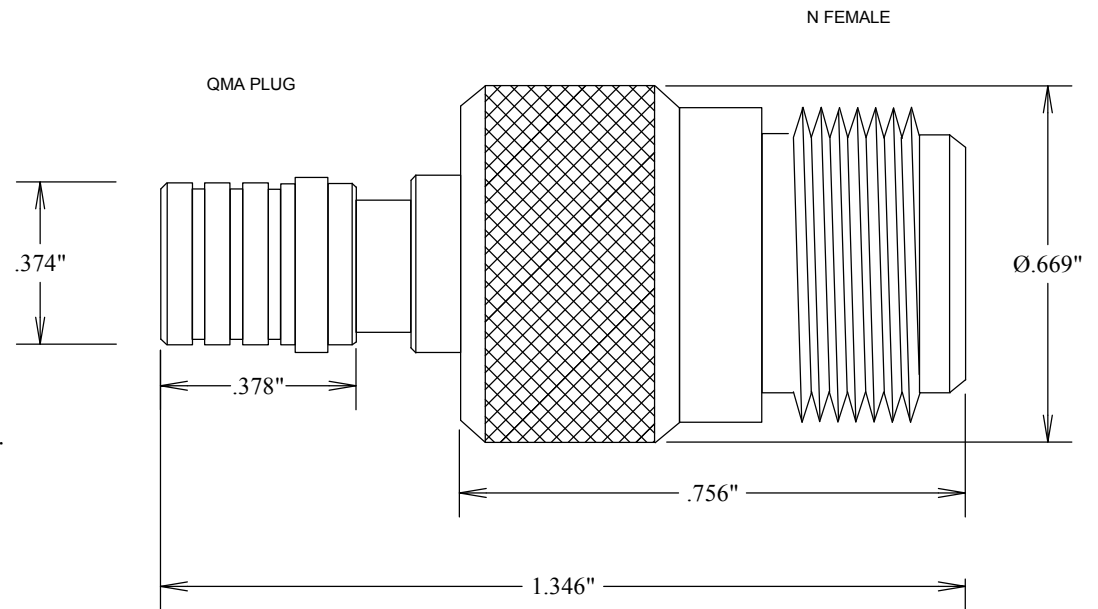

FAIRVIEW MICROWAVE INC.

ALLEN, TX 75013 WWW.FAIRVIEWMICROWAVE.COM

TITLE

QMA/PLUG-N FEMALE ADAPTER

SIZE	CAGE CODE	DWG NO	REV
A	3FKR5	SM5574	--
SCALE			SHEET