

SMA - SMA FLANGE ADAPTER

SM4959

SPECIFICATIONS

ELECTRICAL

FREQUENCY: 0-18 GHZ
 IMPEDANCE: 50 OHMS
 VSWR: 1.20:1 MAX

MECHANICAL

MATERIALS BODY PASS. STAINLESS STEEL
 MATERIALS CONTACTS Au PLATING MIL-G-45204
 DURABILITY: 500 CYCLES MIN

ROHS COMPLIANT

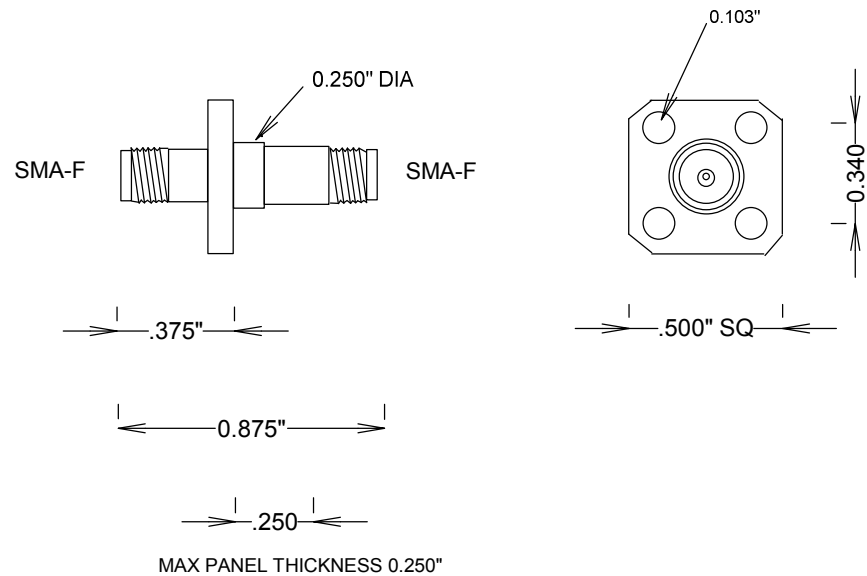

				FAIRVIEW MICROWAVE INC.	
				ALLEN, TX 75013 WWW.FAIRVIEWMICROWAVE.COM	
				TITLE	
				SMA - SMA FLANGE ADAPTER	
SIZE	CAGE CODE	DWG NO	REV		
A	3FKR5	SM4959	B		
SCALE				SHEET	