

# SMA/SMA HERMETIC ADAPTER 18GHZ

SM4918, SM4944

## SPECIFICATIONS

### ELECTRICAL

50 OHMS

VSWR 1.20:1 MAX @ 12.4 GHZ;

1.35:1 MAX @ 18GHZ

FREQUENCY: 0-18 GHZ

### MECHANICAL

500 CYCLES MIN

7-9 LBS COUPLING NUT MATING TORQUE

INTERFACE: MIL-STD-348A

### ENVIRONMENTAL

-55 TO +125 °C

CORROSION: MIL-STD 202

VIBRATION: MIL-STD 202

LEAK RATE: 1 X 10(-7) CC/SEC

### MATERIALS

SM4918: PASSIVATED STAINLESS STEEL

SM4944: GOLD PLATED STAINLESS STEEL

CONTACTS: BeCu

CENTER CONTACTS Au PLATED MIL-G-45204

INSULATOR: TEFLON

ROHS COMPLIANT

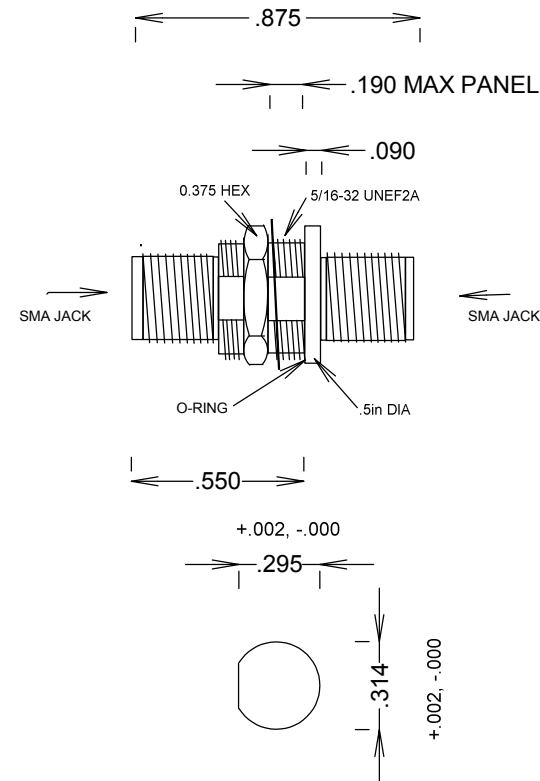

SM4918 PASSIVATED  
SM4944 Au PLATED

RECOMMENDED PANEL CUTOUT

## FAIRVIEW MICROWAVE INC.

ALLEN, TX 75013 WWW.FAIRVIEWMICROWAVE.COM

TITLE

SMA/SMA HERMETIC ADAPTER 18GHZ

SIZE	CAGE CODE	DWG NO	REV
A	3FKR5	SM4918, SM4944	D

SCALE

SHEET