

SMA F/F BULKHEAD ADAPTER W O-RING 18GHZ

SM4933

SPECIFICATIONS

ELECTRICAL

50 OHMS
 VSWR 1.25:1 MAX @ 18 GHZ
 FREQUENCY: 0-18 GHZ

MECHANICAL

500 CYCLES MIN
 7-10 LBS COUPLING NUT MATING TORQUE
 INTERFACE: MIL-STD-348A

ENVIRONMENTAL

-55°C TO +125°C
 CORROSION: MIL-STD 202
 VIBRATION: MIL-STD 202

MATERIALS PASSIVATED STAINLESS STEEL

BODY: SST ASTM A484 / A582
 CONTACTS: BeCu ATSM-B-196
 CONTACTS Au PLATED MIL-G-45204
 INSULATION: TEFLON

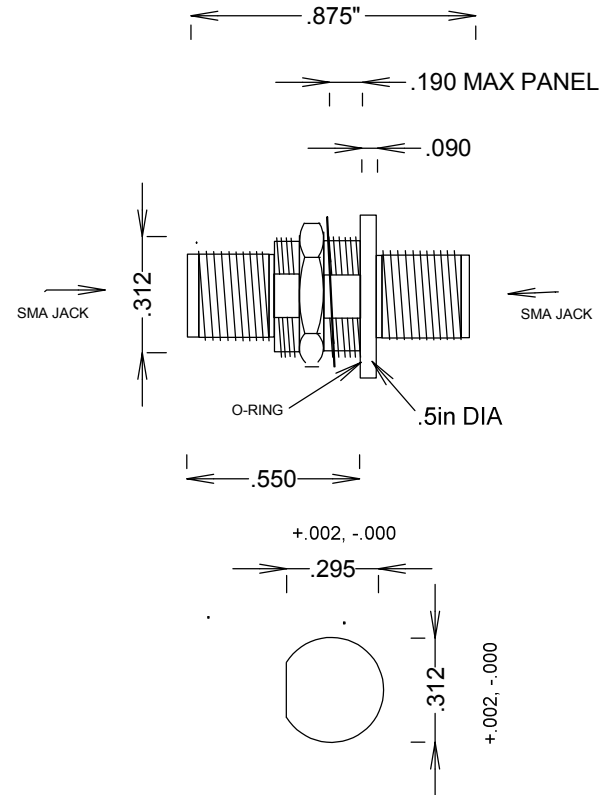

RECOMMENDED PANEL CUTOUT

FAIRVIEW MICROWAVE INC.

ALLEN, TX 75013 WWW.FAIRVIEWMICROWAVE.COM

TITLE

**SMA F/F BULKHEAD ADAPTER
 W O-RING 18GHZ**

SIZE	CAGE CODE	DWG NO	REV
A	3FKR5	SM4933	B
SCALE	SHEET		