

SMA/F-SSMA/P ADAPTER 25GHZ

SM4891

SPECIFICATIONS

ELECTRICAL
50 OHMS
VSWR 1.30:1 MAX @ 25 GHZ
FREQUENCY: 0-25 GHZ

MECHANICAL
500 CYCLES MIN
INTERFACE: MIL-STD-348A

ENVIRONMENTAL
-65 DEG C TO +125 DEG C

MATERIALS BODY: STAINLESS STEEL
BODY PLATING: Au
CONTACTS: BeCu ATSM-B-196
CONTACT PLATING: Au MIL-G-45204

ROHS COMPLIANT

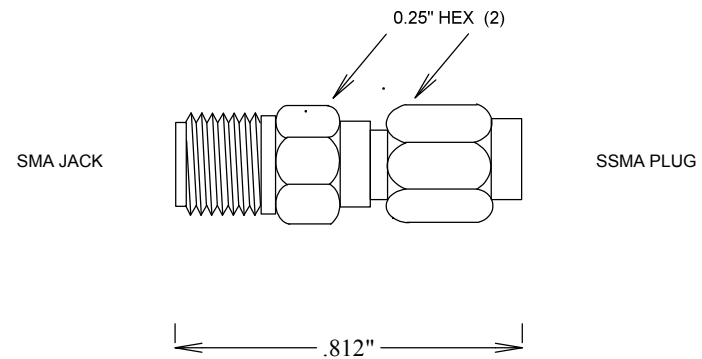

FAIRVIEW MICROWAVE INC.

ALLEN, TX 75013 WWW.FAIRVIEWMICROWAVE.COM

TITLE

SMA/F-SSMA/P ADAPTER 25GHZ

SIZE	CAGE CODE	DWG NO	REV
A	3FKR5	SM4891	--

SCALE	SHEET
-------	-------