

HN-F TO N-F FLANGE ADAPTER

SM4633

SPECIFICATIONS

ELECTRICAL

FREQUENCY: 0-4 GHZ
IMPEDANCE: 50 OHMS
VSWR: 1.2:1 MAX

MECHANICAL

MATERIAL BODY: NICKEL PLATED BRASS
CONTACTS MALE: BRASS
CONTACT PLATING: Si QQ-S-365
INSULATOR: TEFLON
INTERFACE: MIL-STD-348
ROHS COMPLIANT

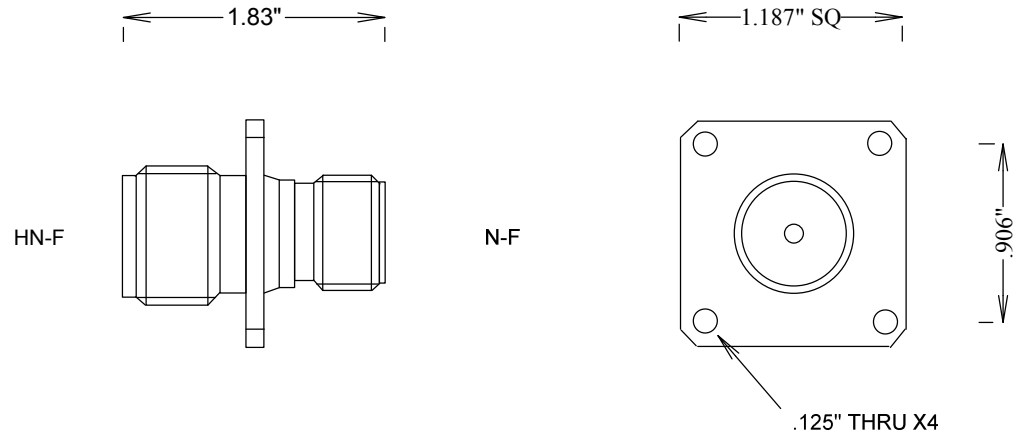

FAIRVIEW MICROWAVE INC.

ALLEN, TX 75013 WWW.FAIRVIEWMICROWAVE.COM

TITLE

HN-F TO N-F FLANGE ADAPTER

SIZE	CAGE CODE	DWG NO	REV
A	3FKR5	SM4633	--

SCALE

SHEET