

N-N M/F 18GHZ FLANGE ADAPTER

SM4039

SPECIFICATIONS

ELECTRICAL

FREQUENCY: 0-18 GHZ
 IMPEDANCE: 50 OHMS
 VSWR: 1.15:1 MAX

MECHANICAL

MATERIALS BODY PASS STAINLESS STEEL
 MATERIALS CONTACTS BeCu
 CONTACT PLATING: Au PER MIL-G-45204
 INTERFACE: MIL-STD-348A
 DURABILITY: 500 CYCLES MIN

ENVIRONMENTAL

TEMP: -55 TO +125 DEG C

ROHS COMPLIANT

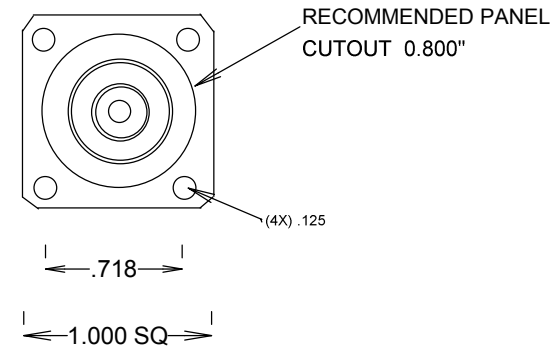
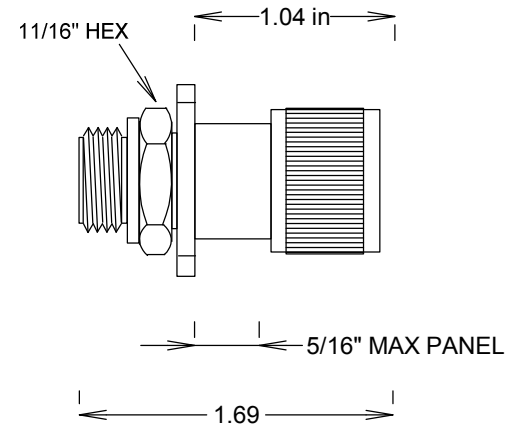

****Note:** Hex nut is stationary, does not come off. Cutout must be 0.8"

				FAIRVIEW MICROWAVE INC.	
				ALLEN, TX 75013 WWW.FAIRVIEWMICROWAVE.COM	
				TITLE	
				N-N M/F 18GHZ FLANGE ADAPTER	
		SIZE	CAGE CODE	DWG NO	REV
		A	3FKR5	SM4039	B
				SCALE	SHEET