

# TNC/F-BNC/M R ANGLE ADAPTER

SM3559

## SPECIFICATIONS

### ELECTRICAL

FREQUENCY: 0-4 GHZ  
IMPEDANCE: 50 OHMS  
VSWR: 1.25:1 MAX @ 4GHZ

### MECHANICAL

MATERIAL BODY: NICKEL PLATED BRASS  
MATERIAL CONTACTS: BeCu (f), BRASS (m)  
CONTACT PLATING: Au MIL-G-45204  
INSULATOR: TEFLON  
INTERFACE: MIL-STD-348B

TEMP RANGE: -55 TO +125°C

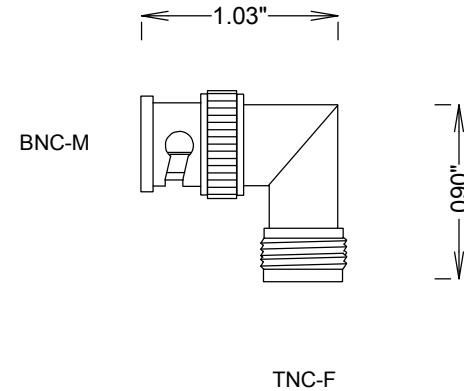

**FAIRVIEW MICROWAVE INC.**

ALLEN, TX 75013 WWW.FAIRVIEWMICROWAVE.COM

TITLE

**TNC/F-BNC/M R ANGLE ADAPTER**

SIZE	CAGE CODE	DWG NO	REV
<b>A</b>	3FKR5	<b>SM3559</b>	-

SCALE

SHEET