

3.5mm F/F BULKHEAD ADAPTER 34 GHZ

SM3312

SPECIFICATIONS

ELECTRICAL
 50 OHMS
 VSWR 1.25:1 MAX @ 34 GHZ
 FREQUENCY: 0-34 GHZ

MECHANICAL
 500 CYCLES MIN
 4.0 INCH-OUNCES MIN CONTACT TORQUE
 8-10 LBS COUPLING NUT MATING TORQUE

ENVIRONMENTAL
 -65 DEG C TO +85 DEG C
 CORROSION: MIL-STD 202
 VIBRATION: MIL-STD 202

MATERIALS PASSIVATED STAINLESS STEEL
 BODY: SST ASTM A484 / A582
 BeCu ATSM-B-196
 PASSIVATED ASTM A380
 CENTER CONTACTS Au PLATED
 MIL-G-45204

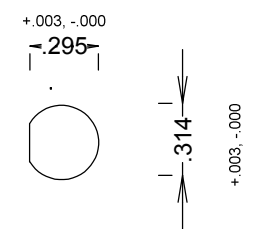
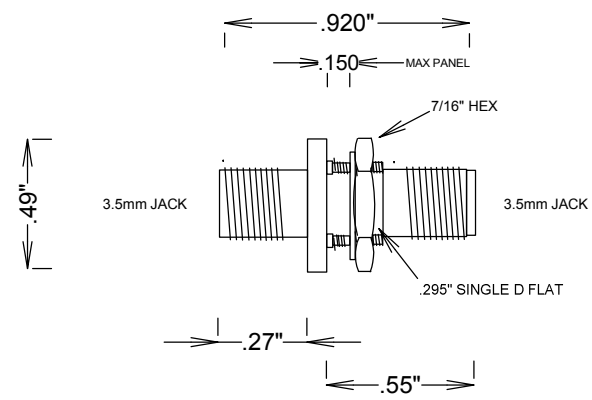

RECOMMENDED PANEL CUTOUT

				FAIRVIEW MICROWAVE INC.	
				ALLEN, TX 75013 WWW.FAIRVIEWMICROWAVE.COM	
				TITLE	
				3.5mm F/F BULKHEAD ADAPTER 34 GHZ	
SIZE	CAGE CODE	DWG NO			
A	3FKR5	SM3312	REV E		
SCALE			SHEET		