

BMA (OSP) TO SMA ADAPTERS

SM3297

SPECIFICATIONS

ELECTRICAL

FREQUENCY: 0-18 GHZ
 IMPEDANCE: 50 OHMS
 VSWR 1.15:1 MAX
 (BMA GOOD TO 22GHZ;
 SMA MAY MODE ABOUT 20.5GHZ)

MECHANICAL

DURABILITY: 500 CYCLES MIN.
 TEMPERATURE RANGE: -65 TO +125 DEG C

MATERIALS

BODY PASS STAINLESS STEEL
 CONTACTS Au PLATING

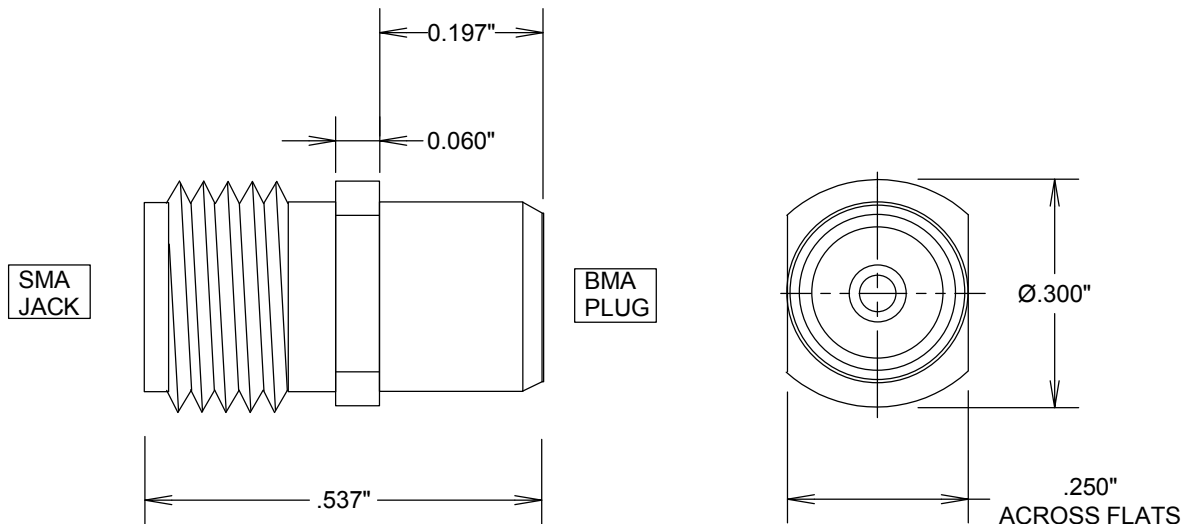

				FAIRVIEW MICROWAVE INC.	
				ALLEN, TX 75013 WWW.FAIRVIEWMICROWAVE.COM	
				TITLE	
				BMA (OSP) TO SMA ADAPTERS	
SIZE	CAGE CODE	DWG NO	SM3297		
A	3FKR5				
SCALE			SHEET		REV A