

BMA (OSP) TO SMA ADAPTERS

SM3294

SPECIFICATIONS

ELECTRICAL

FREQUENCY: 0-12 GHZ
 IMPEDANCE: 50 OHMS
 VSWR 1.15:1 MAX

MECHANICAL

DURABILITY: 500 CYCLES MIN.
 TEMPERATURE RANGE: -65 TO +125 DEG C

MATERIALS

BODY PASS STAINLESS STEEL
 CONTACTS Au PLATING

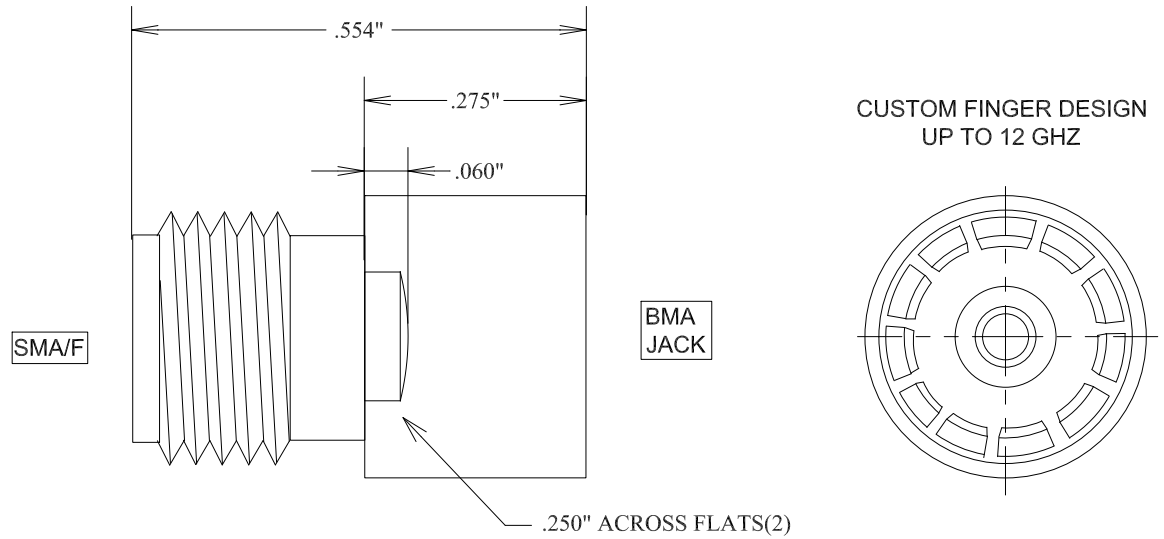

FAIRVIEW MICROWAVE INC.

ALLEN, TX 75013 WWW.FAIRVIEWMICROWAVE.COM

TITLE

BMA (OSP) TO SMA ADAPTERS

SIZE	CAGE CODE	DWG NO	REV
A	3FKR5	SM3294	--

SCALE

SHEET