

# 2.4mm / 2.4mm F/F BULKHEAD ADAPTER 50 GHZ

SM3015

## SPECIFICATIONS

**ELECTRICAL**  
 50 OHMS  
 VSWR 1.30:1 MAX @ 50 GHZ  
 FREQUENCY: 0-50 GHZ

**MECHANICAL**  
 500 CYCLES MIN  
 4.0 INCH-OUNCES MIN CONTACT TORQUE  
 8-10 LBS COUPLING NUT MATING TORQUE

**ENVIRONMENTAL**  
 -55 DEG C TO +100 DEG C  
 CORROSION: MIL-STD 202  
 VIBRATION: MIL-STD 202

**MATERIALS PASSIVATED STAINLESS STEEL**  
 BODY: SST ASTM A484 / A582  
 BeCu ATSM-B-196  
 PASSIVATED ASTM A380  
 CENTER CONTACTS Au PLATED  
 MIL-G-45204

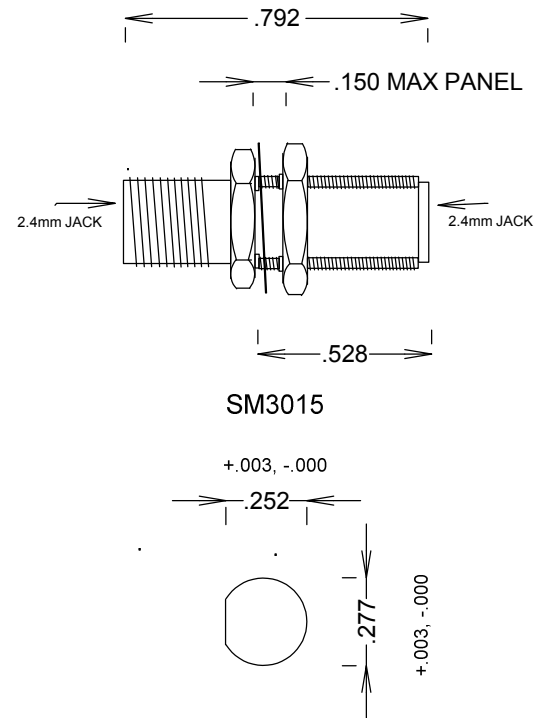

RECOMMENDED PANEL CUTOUT

**FAIRVIEW MICROWAVE INC.**

ALLEN, TX 75013 WWW.FAIRVIEWMICROWAVE.COM

TITLE

2.4mm / 2.4mm F/F BULKHEAD ADAPTER 50 GHZ

SIZE	CAGE CODE	DWG NO	REV
<b>A</b>		<b>SM3015</b>	<b>C</b>

SCALE	SHEET
-------	-------