

SMA F'S CIRCULATOR 1700-2400 MHZ

SFC1724S

SPECIFICATIONS

ELECTRICAL

FREQUENCY: 1700-2400 MHZ
IMPEDANCE: 50 OHMS
VSWR: 1.3:1 MAX
INSERTION LOSS: 0.5 DB MAX
AVG POWER : 10 W
ISOLATION: 17 DB TYP;

MECHANICAL

MATERIAL CONNECTORS: STAINLESS STEEL
MATERIAL CONTACTS: Au PLATED BeCu
MATERIAL HOUSING: ALUMINUM
MATERIAL MAGNET: FeNi SOFT MAGNETIC ALLOY

TYPICAL TEST TEMP: +25°C

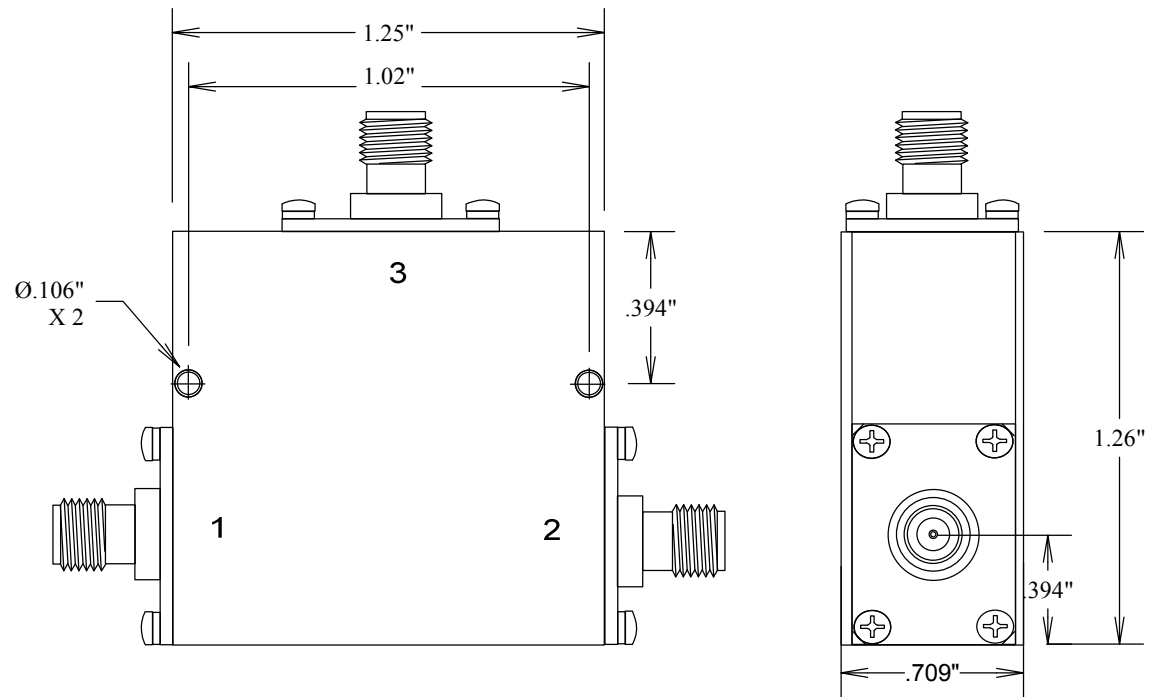

FAIRVIEW MICROWAVE INC.

ALLEN, TX 75013 WWW.FAIRVIEWMICROWAVE.COM

TITLE

SMA F'S CIRCULATOR 1700-2400 MHZ

SIZE	CAGE CODE	DWG NO	REV
A	3FKR5	SFC1724S	--
SCALE	SHEET		