

SC7237 ASSEMBLY INSTRUCTIONS

1.0 TRIM CABLE PER STRIPPING DIMENSIONS.

2.0 SLIDE CLAMP NUT OVER CABLE AS ILLUSTRATED.

2.1 INSERT CABLE INTO SOLDER FERRULE UNTIL CABLE DIELECTRIC IS FLUSH WITH FACE OF FERRULE THEN SOLDER BRAIDS AS SHOWN.

2.2 SLIDE DIELECTRIC STOP OVER CABLE CENTER IN ORDER TO SOLDER CONTACT FLUSH AGAINST STOP PER DIMENSIONS SHOWN.

3.0 INSERT FORWARD INSULATOR IN CONNECTOR IN ORIENTATION SHOWN.

3.1 INSERT CABLE/CONTACT SUBASSEMBLY UNTIL COMPLETELY SEATED.

3.2 TIGHEN REAR CLAMP NUT TO 35 TO 45 INCH LBS

1.

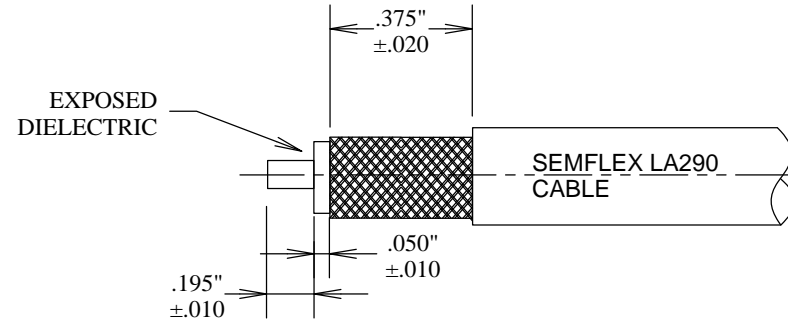

2.

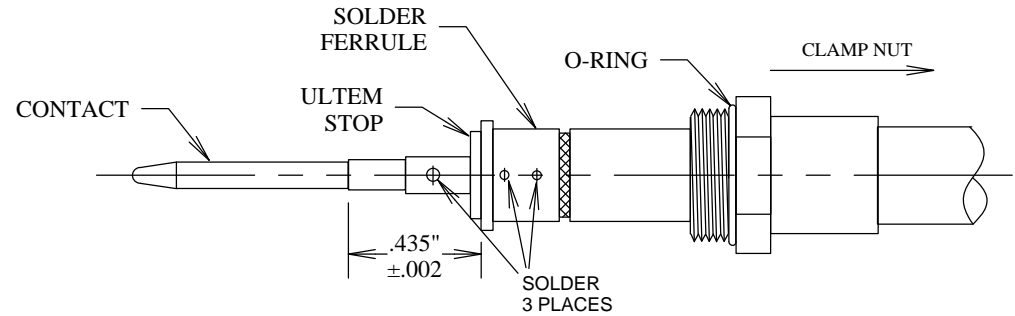

3.

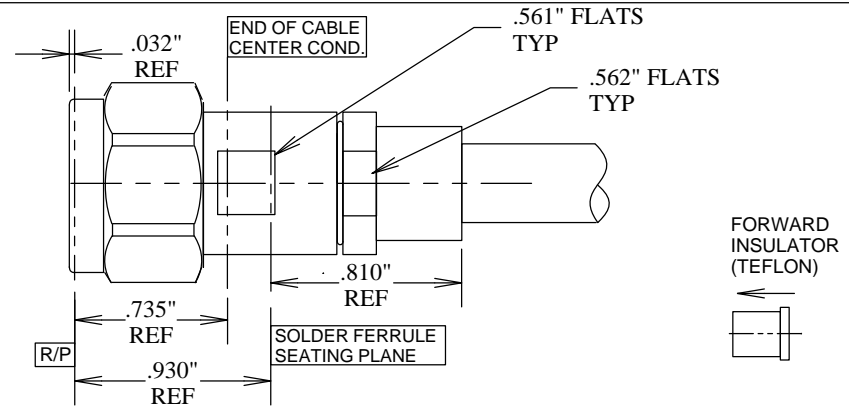

FAIRVIEW MICROWAVE INC.

ALLEN, TX 75013 WWW.FAIRVIEWMICROWAVE.COM

TITLE

SC7237 ASSEMBLY INSTRUCTIONS

SIZE	CAGE CODE	DWG NO	REV
A	3FKR5	SC7237 AI	--

SCALE

SHEET