

SC7233 ASSEMBLY INSTRUCTIONS

- 1.0 TRIM CABLE PER STRIPPING DIMENSIONS.
- 2.0 SLIDE CLAMP NUT OVER CABLE AS ILLUSTRATED.
- 2.1 INSERT CABLE INTO SOLDER FERRULE THEN SOLDER BRAIDS TO FERRULE AS SHOWN.
- 2.2 TRIM EXPOSED CABLE DIELECTRIC FLUSH WITH SOLDER FERRULE FACE.
- 2.3 SLIDE DIELECTRIC STOP OVER CABLE CENTER CENTER CONDUCTOR AGAINST FERRULE FACE IN ORDER TO SOLDER CONTACT FLUSH AGAINST STOP PER DIMENSIONS SHOWN.
- 3.0 INSERT CABLE/CONTACT SUBASSEMBLY UNTIL COMPLETELY SEATED.
- 3.1 TIGHTEN COUPLING NUT TO MATING N JACK.
- 3.2 TIGHEN REAR CLAMP NUT TO 30 TO 40 INCH LBS AND DISENGAGE MAIN INTERFACE FROM JACK.

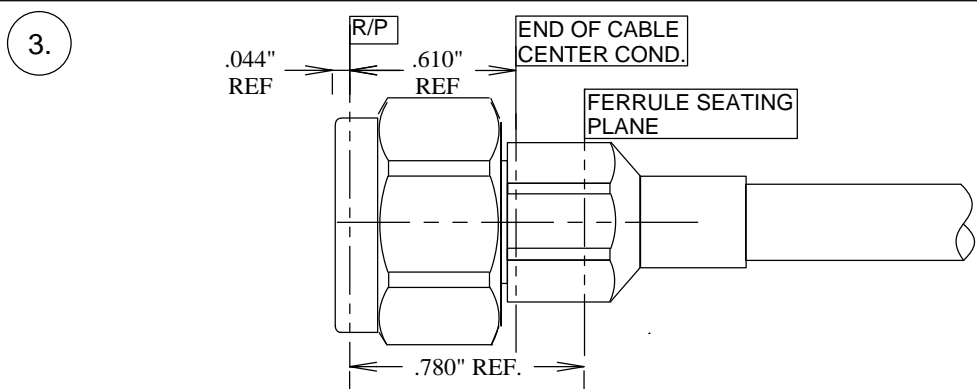
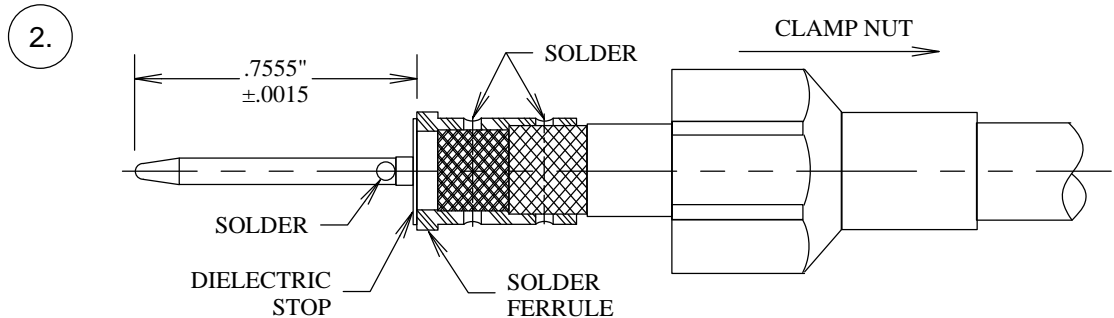
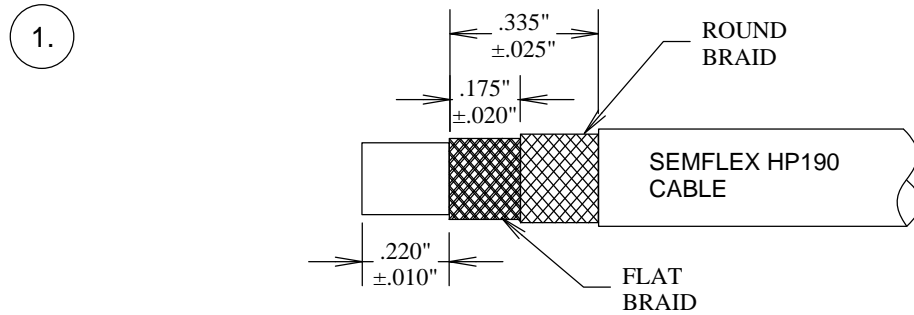

FAIRVIEW MICROWAVE INC.

ALLEN, TX 75013 WWW.FAIRVIEWMICROWAVE.COM

TITLE

SC7233 ASSEMBLY INSTRUCTIONS

SIZE	CAGE CODE	DWG NO	REV
A	3FKR5	SC7233 AI	--
SCALE		SHEET	