

# ATTENUATORS N 50 WATTS 3GHZ M/F STAINLESS STEEL CONNECTORS

SA3N50-XX-1

## SPECIFICATIONS

### ELECTRICAL:

FREQUENCY: 0-3 GHZ  
 VSWR @ 1 GHZ: 1.15:1 MAX  
 VSWR @ 2.4 GHZ: 1.2:1 MAX  
 VSWR @ 3 GHZ: 1.25 MAX  
 POWER (AVG) 50 WATTS @ 25 DEG C  
 POWER (PEAK) 2000 WATTS  
 ATTENUATION ACCURACY: GREATER OF  
 +/-0.5DB OR 3%  
 IMPEDANCE: 50 OHMS

### MATERIALS

MATERIAL CONNECTORS: STAINLESS STEEL

### ENVIRONMENTAL:

TEMP: -55 C TO +125 C

ROHS COMPLIANT

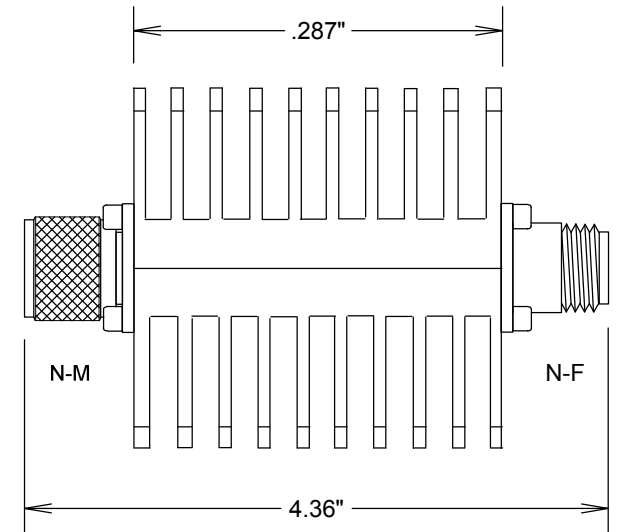
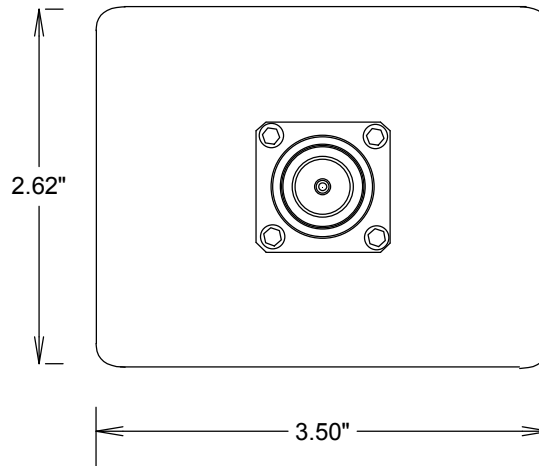

				<b>FAIRVIEW MICROWAVE INC.</b>	
				ALLEN, TX 75013 WWW.FAIRVIEWMICROWAVE.COM	
				TITLE	
				ATTENUATORS N 50 WATTS 3GHZ M/F STAINLESS STEEL CONNECTORS	
SIZE	CAGE CODE	DWG NO		REV	
A	3FKR5	SA3N50-XX-1			
SCALE			SHEET		