

ATTENUATOR N-M/F 100 WATTS 3GHZ

SA3N-100

SPECIFICATIONS

ELECTRICAL:

FREQUENCY: 0-3 GHZ
 VSWR @ 1GHZ: 1.15 MAX
 VSWR @ 3 GHZ: 1.3:1 MAX
 POWER (AVG) 100 WATTS @ 25 DEG C
 POWER (PEAK) 2000 WATTS
 IMPEDANCE: 50 OHM

CONNECTORS:

Ni PLATED BRASS
 PLATING: Au PER MIL-G-45204
 FEMALE CONTACTS: BeCu
 INSULATOR: TEFLON

ENVIRONMENTAL:

TEMP: -55 C TO +125 C
 ROHS COMPLIANT

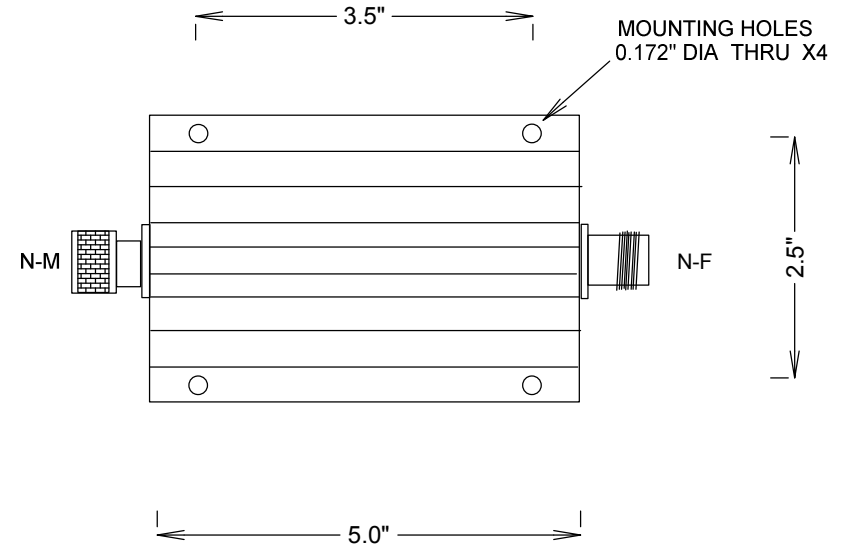
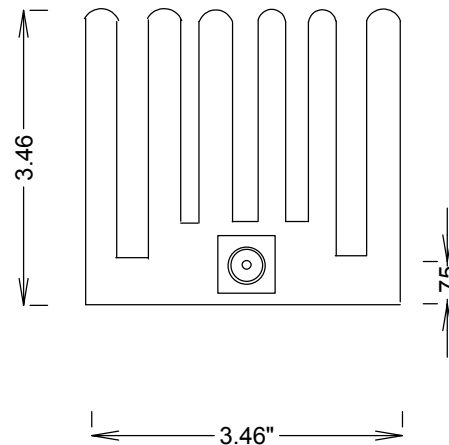

				FAIRVIEW MICROWAVE INC.	
				ALLEN, TX 75013 WWW.FAIRVIEWMICROWAVE.COM	
				TITLE	
				ATTENUATOR N-M/F 100 WATTS 3GHZ	
SIZE		CAGE CODE	DWG NO.		REV
A		3FKR5	SA3N-100		A
SCALE					SHEET