

SMA/MALE SMA/FEMALE REVERSE POLARITY 3 GHZ ATTENUATOR

SA3R-XX

SPECIFICATIONS

ELECTRICAL:

FREQUENCY: 0-3 GHZ
 VSWR 1.25 MAX TO 3 GHZ
 POWER (AVG) 2 WATTS @ 25° C
 POWER (PEAK) 100 WATTS
 POWER COEFFICIENT: 0.001dB/W

ATTENUATION ACCURACY:		
	DC-2GHz	2-3GHz
6dB-20dB	±0.2 dB	±0.3 dB

IMPEDANCE: 50 OHMS

MECHANICAL:

MATERIAL BODY: NICKEL PLATED BRASS
 MATERIAL CONTACT: PHOSPHOR BRONZE
 CONTACT PLATING: NICKEL

ENVIRONMENTAL:

TEMP: -50°C TO +80°C

ROHS COMPLIANCE

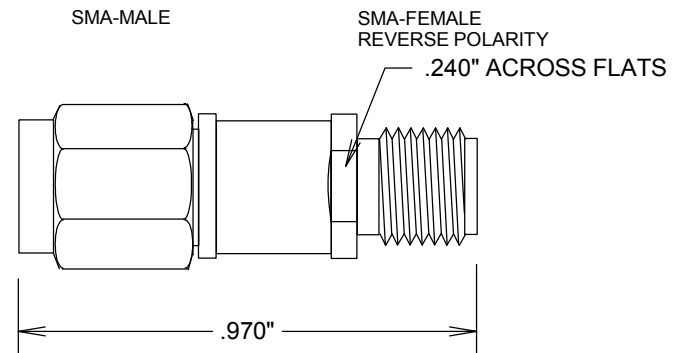

				FAIRVIEW MICROWAVE INC.	
				ALLEN, TX 75013 WWW.FAIRVIEWMICROWAVE.COM	
				TITLE	
				SMA/MALE SMA/FEMALE REVERSE POLARITY 3 GHZ ATTENUATOR	
SIZE	CAGE CODE	DWG NO	REV		
A	3FKR5	SA3R-XX	--		
SCALE			SHEET		